



Ramkrishna Forgings Limited



Corporate Presentation : May 2023



About Ramkrishna Forgings

One of the largest forging player in India



Key Highlights



Manufacturer and supplier of a variety of auto and non-auto components



Global presence with sales & support office across 4 continents

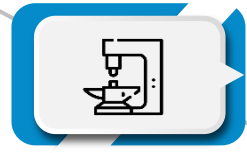

2nd largest forging player in India with over 40 years of experience



Promoter possessing multi-decade forgings industry experience

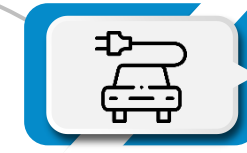

Continued focus on diversification with foray into EV



Longstanding relationship with marquee customers

Vision, Mission & Core Values

Vision

To be the most dependable and preferred supplier of forged and rolled components for the railways, automobile, mining, earthmoving, oil exploration, farm equipment, bearing and general engineering industry by providing world class products at competitive prices through a knowledge-based organization

Mission

Create value for all business associates, shareholders and customers in all the areas of business in which we are associated with and to become an active partner in employee well-being and philanthropic causes

Core Values

Customer centric approach
Continual improvements in systems
Commitment to human development

... with over four decades of unique capabilities

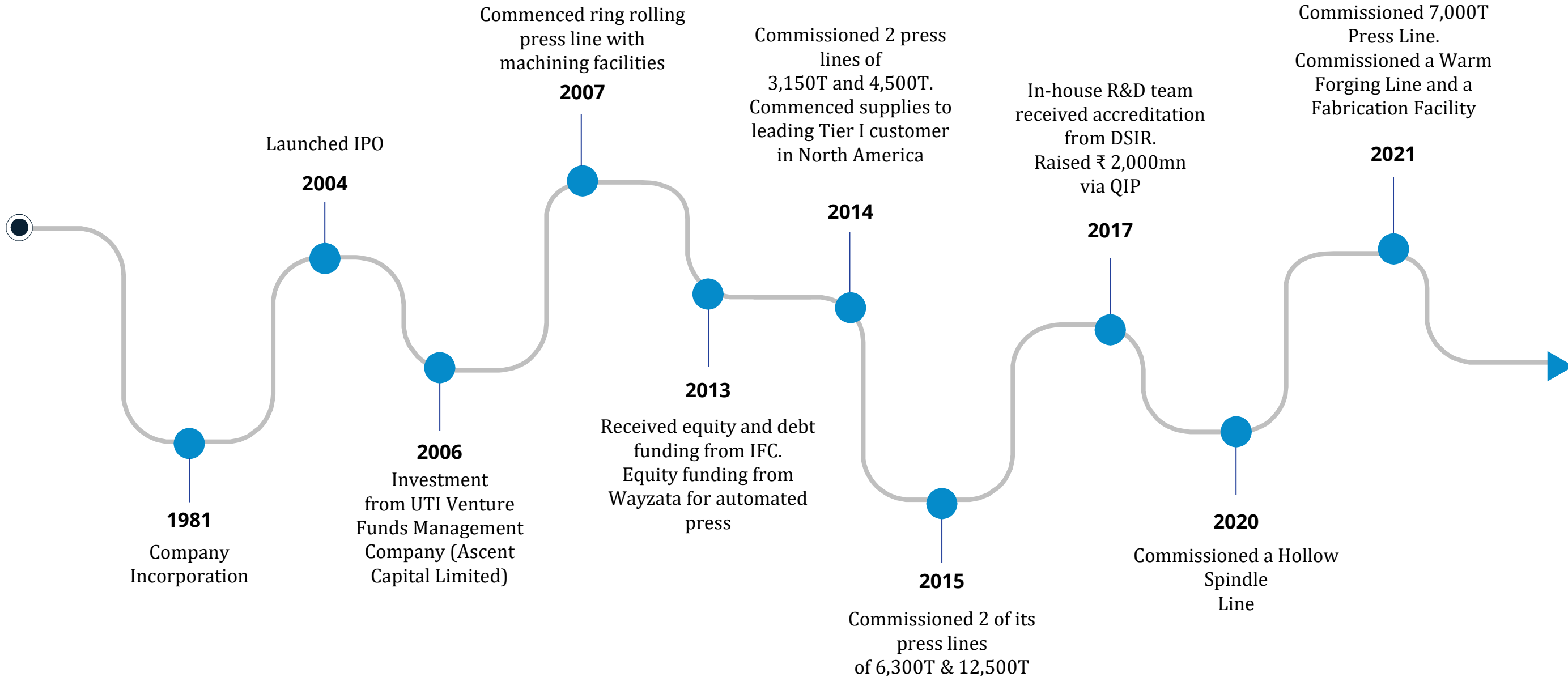

... with state of the art manufacturing facilities



Ring Rolling

- Ring Rolling facility with robotics which can roll crown wheels upto 500mm diameter and a capacity to forge components from 15-70 kgs
- Ability to forge one component in 25-40seconds



Press

- First company in India to have fully automated 12,500T wedge press line
- Capability to manufacture complex and heavy forged components



Machined

- State of the art machinery and capabilities which includes turning Center, gear hobbing, shaping, shaving and broaching.

1 6 large modern facilities in India >> Strategic location benefits coupled with economies of scale

2 Technology led operations better solutions, optimum yield and enhanced quality of products

3 Extensive manufacturing capabilities >> Ability to manufacture diverse products

4 Agile, flexible operations >> Customized customer centric solutions

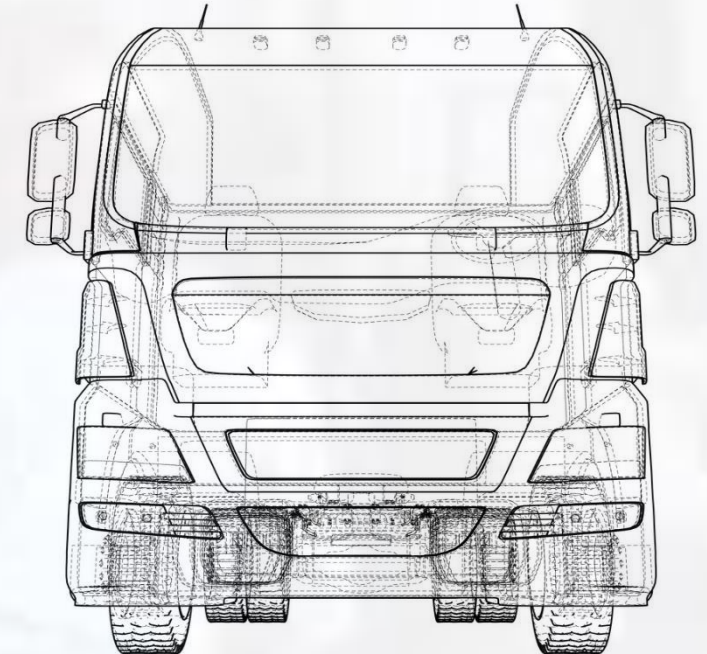

... at strategic locations giving us competitive edge

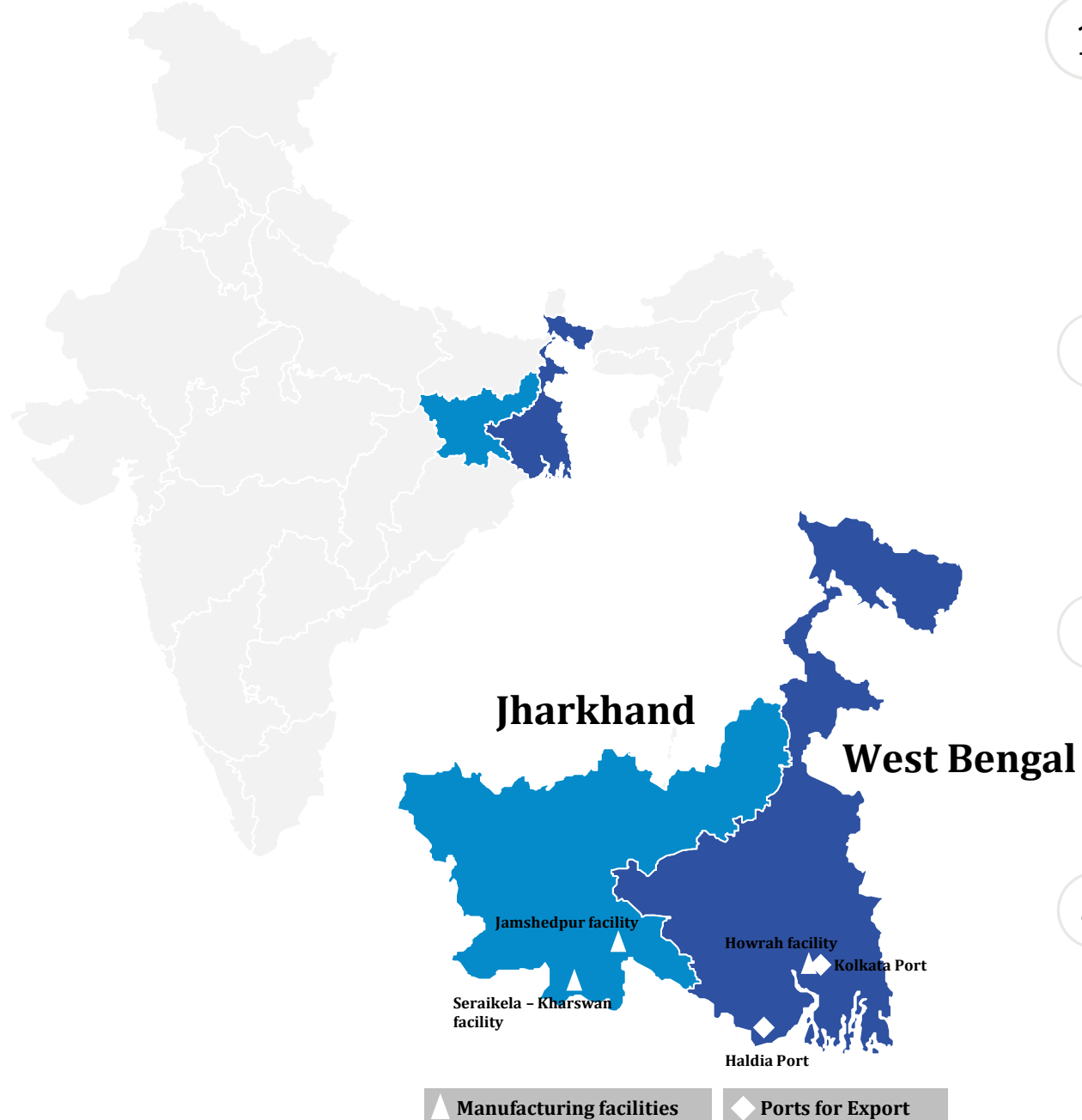

1

Proximity to automobile manufacturing hubs & key suppliers

- RKFL's facilities in eastern India are located in close proximity to automobile manufacturing hubs and key suppliers of raw material
 - Less chance of supply interruptions
 - Lower logistics cost
 - Reduced working capital requirements

2

All facilities located within the same region

- Better integration resulting in efficient processes
- Improved coordination
- Overall cost savings, including administrative costs

3

Proximity to key export hubs

- Reduces logistics cost
 - 302km* to Kolkata port
 - 270km* to Haldia port

4

Availability of labor

- Eastern region is the industrial center of India
- Low cost labor easily available
- Lower dependency on migrant laborers

*approximate distance from Jamshedpur facility

... demonstrating superior performance*



23

Countries Served

1,87,100

Installed Capacity

87%

Capacity Utilisation

1,34,654

Sales Volume
↑ 21% YoY

₹ 3,001 cr

Revenue
↑ 31% YoY

100%

Dividend#

3%

Total Turnover
from EV

₹ 668 cr

EBITDA
↑ 27% YoY

22.3%

EBITDA Margin

19.3%

ROCE

17.8%

ROE

1.6x

Net Debt to EBITDA

*As on 31st March 2023 on standalone financials; #Dividend as % of Face Value of Rs 2 each

... offering diversified products

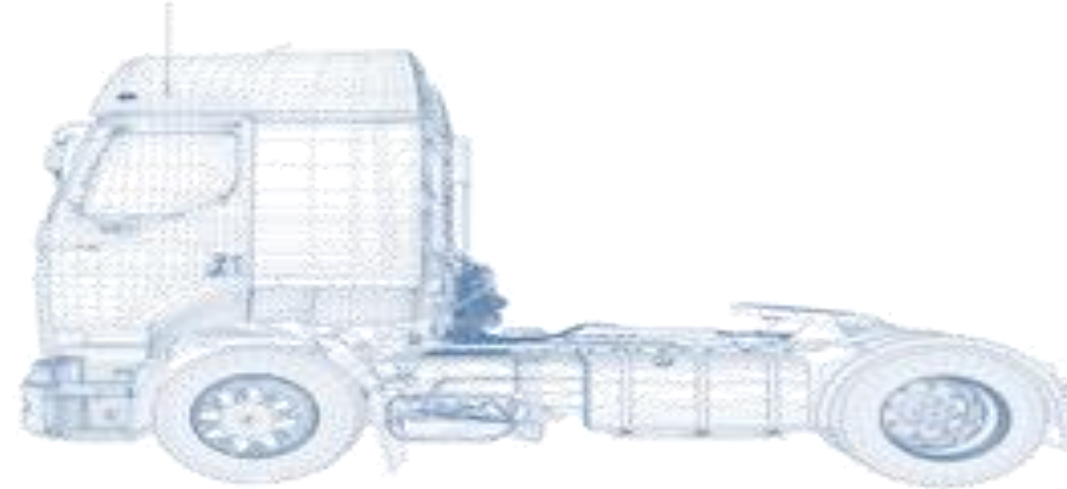

1 Front Axle & Steering



2 Engine



3 Suspension & Chassis

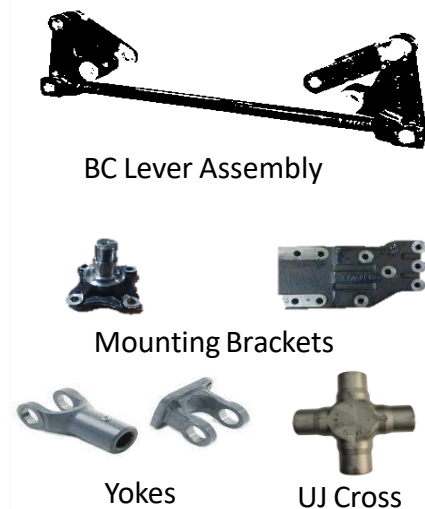

4 Transmission



5 Rear Axle



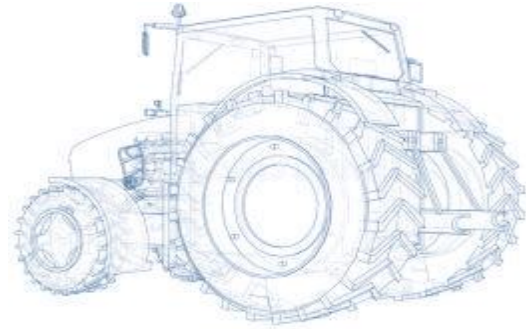

Tractors & Tillers



1,2,3 & 4 Cyl Forged Crankshafts



Crown Wheel & Pinion



Rear Axle Shafts



Transmission Shafts & Gears

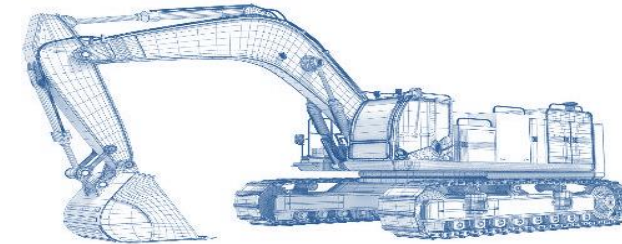

Earth Moving



Bucket



Backhoe Bucket



Shovel



Track Link



Track Roller



Bucket Tooth



Pivot Pin



Prop Shaft



Bearing Centre

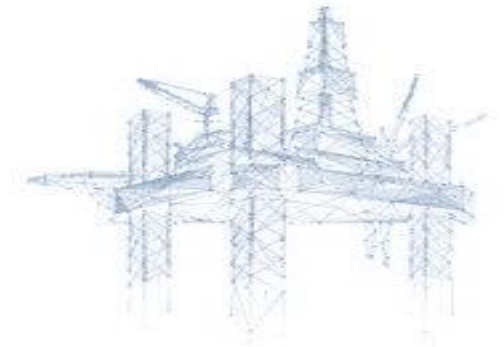
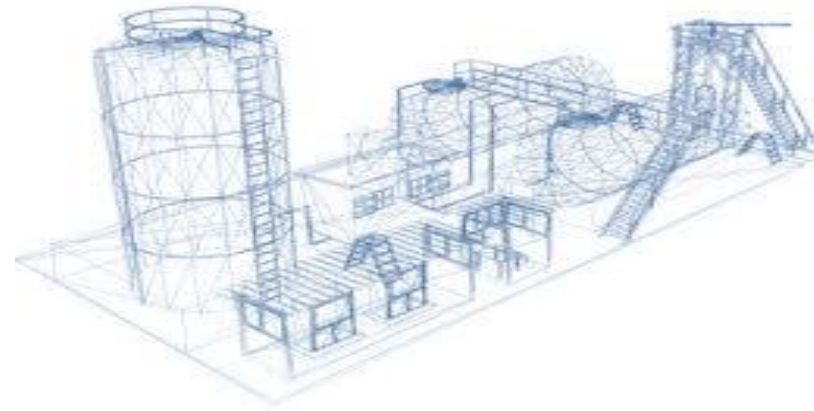
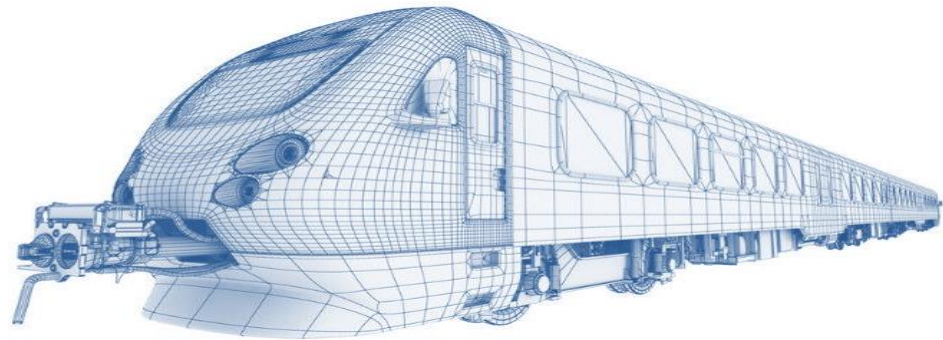

Railways



Bogie Frame



Bogie Bolster



Draw Gear Assembly



Screw Coupling



Hanger

Anti Roll Bar Assembly

Energy



Wing Nut



Valve Bonnet



T Bolt Socket Joint



Toothed Crusher Hammer

... with growing global footprints



(₹ in crores)



Headquarters & Manufacturing facilities

- Headquarters – Kolkata
- 6 manufacturing facilities
 - Jamshedpur – 3
 - Saraikela – Kharsawan – 2
 - Howrah – West Bengal – 1



Sales & support office:

- Detroit, USA
- Sao Paulo, Brazil
- Istanbul, Turkey
- Germany
- Italy



Warehousing facility:

- Shelbyville, USA
- Hagerstown, USA
- Monterrey, Mexico
- Toluca, Mexico
- Westerloo, Belgium
- Indianapolis, USA
- Pubela, Mexico

With consistently growing exports *

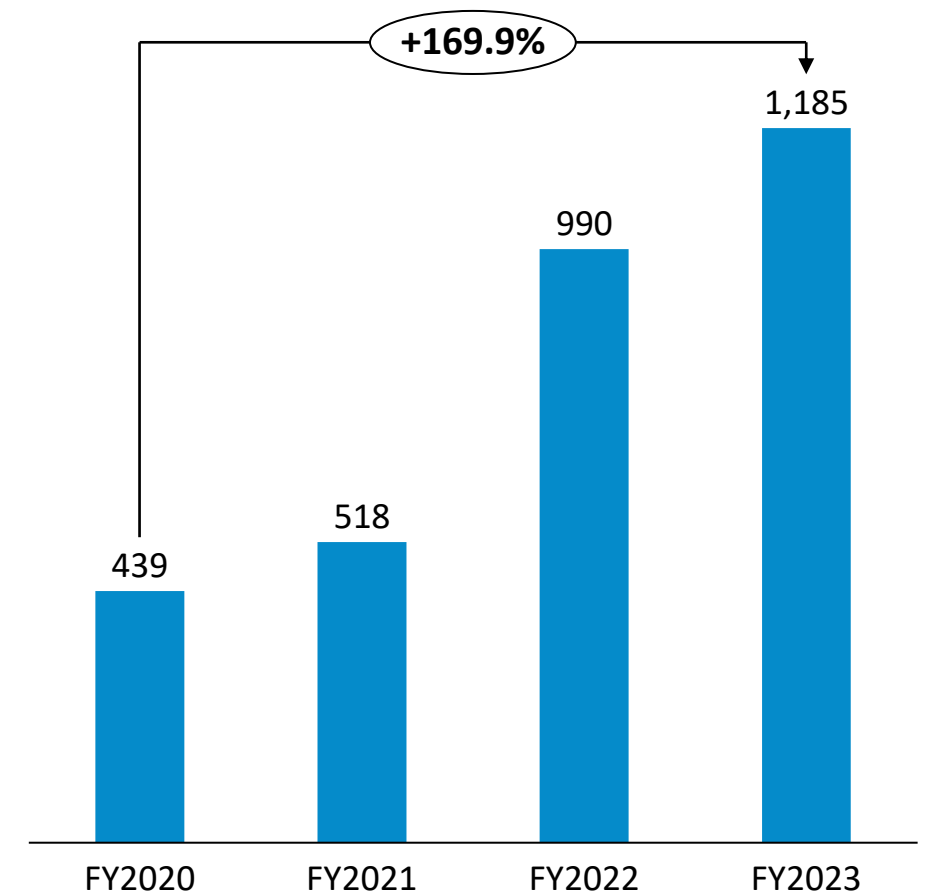

*Export revenue from operations, excluding foreign exchange fluctuations

...with multiple accreditations & certifications



ISO 9001:2015

QMS



IATF 16949:2016

QMS for Automotive
Production



ISO 14001:2015

Environmental
Management



ISO 45001:2018

Occupational Health and
Safety Management



ISO/TS 22163:2017

Quality & Business
Management Systems for Railways



EN 15085-2:2020

Welding of Railway Vehicles and
Components



A decorative background pattern of light gray triangles arranged in a repeating geometric pattern, fading out towards the right side of the slide.

Financial Highlights

Strong growth backed by profitability



(₹ in Lakhs)

(Standalone)

Revenue*

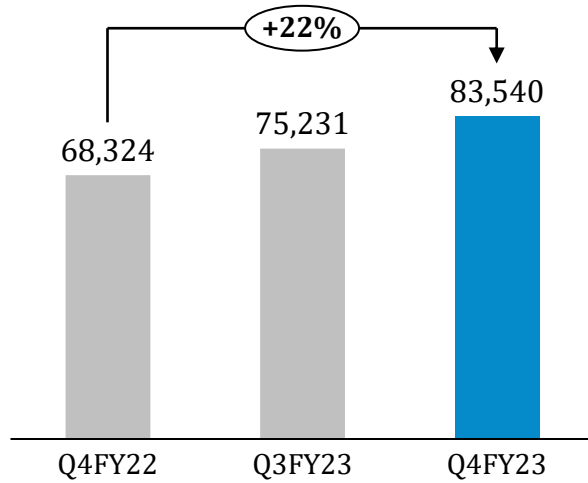

EBITDA* & EBITDA Margin

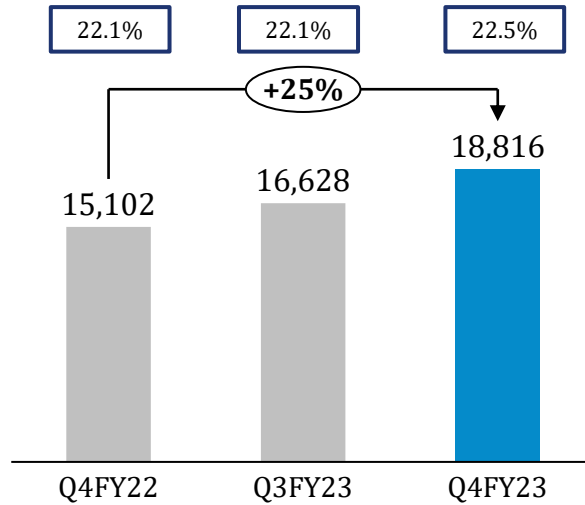

PAT & PAT Margin

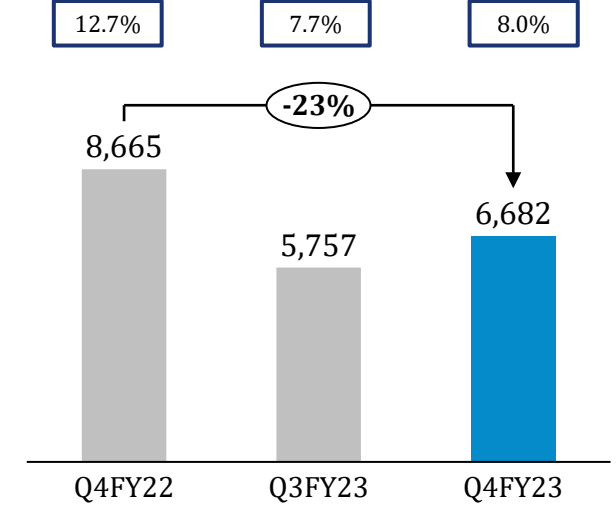

Revenue*

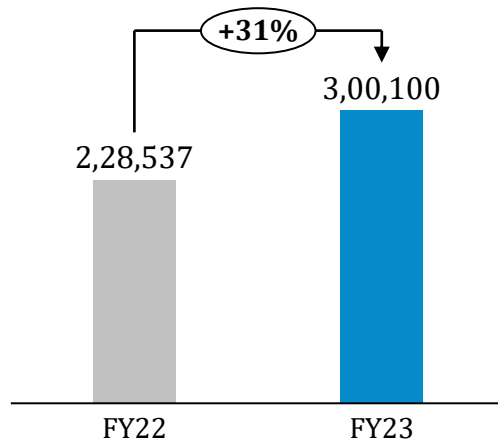

EBITDA* & EBITDA Margin

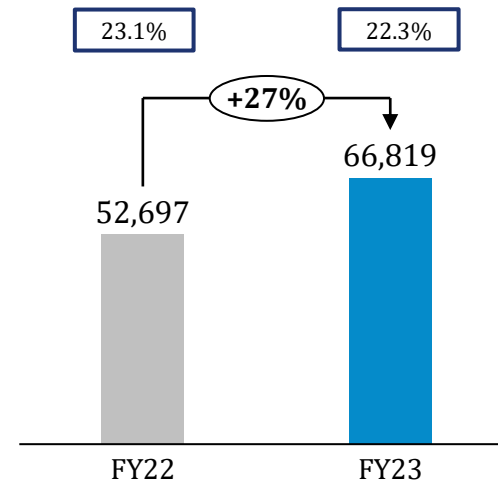

PAT & PAT Margin

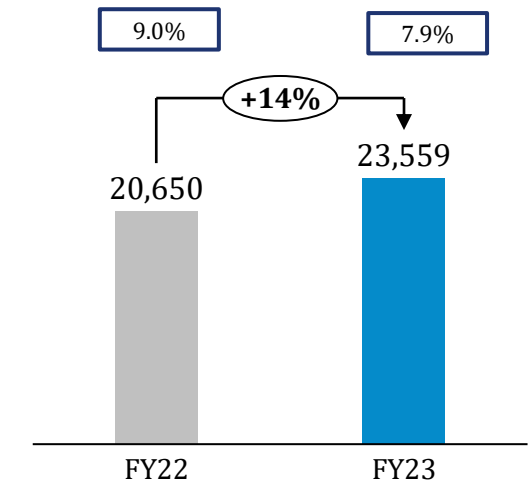

*Excluding Other Income ; Note: Rounded off to the nearest whole number

Strong growth backed by profitability



(₹ in Lakhs)

(Consolidated)

Revenue*

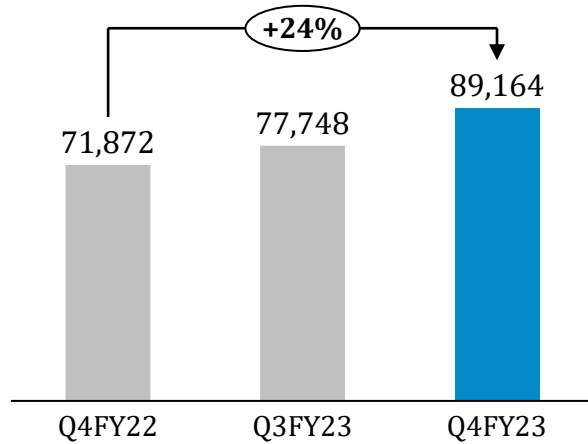

EBITDA* & EBITDA Margin

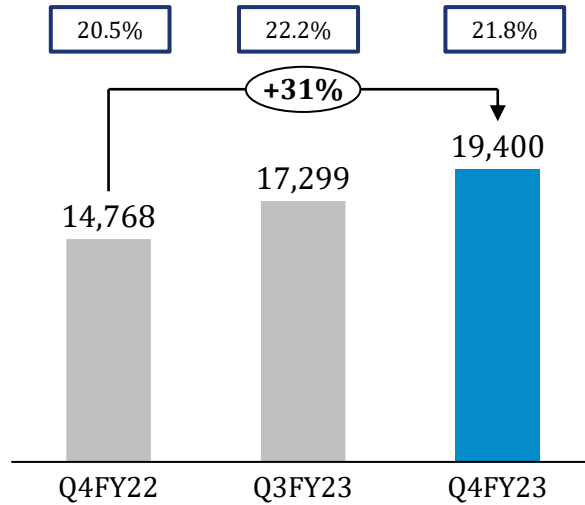

PAT & PAT Margin

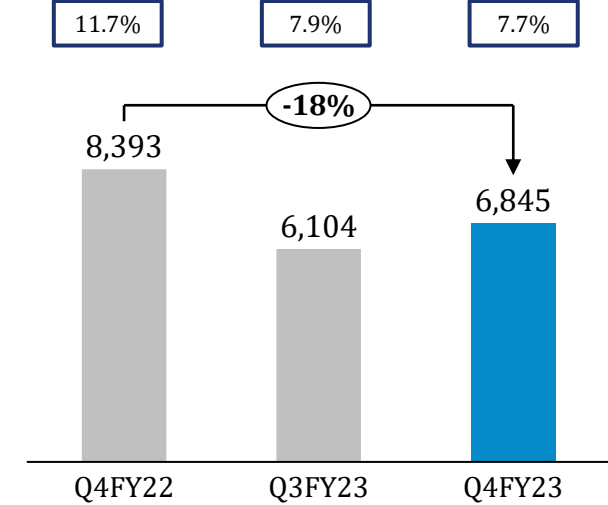

Revenue*

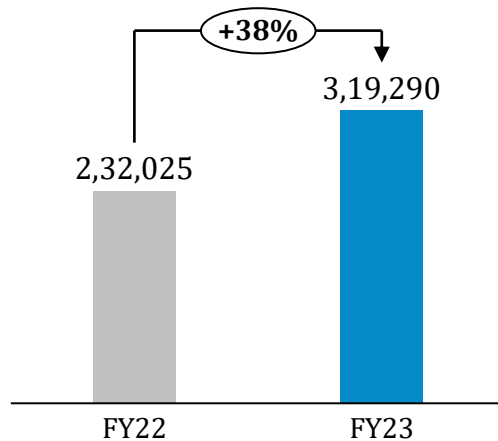

EBITDA* & EBITDA Margin

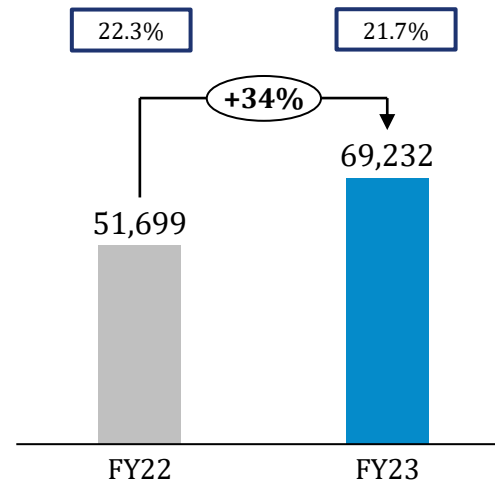

PAT & PAT Margin

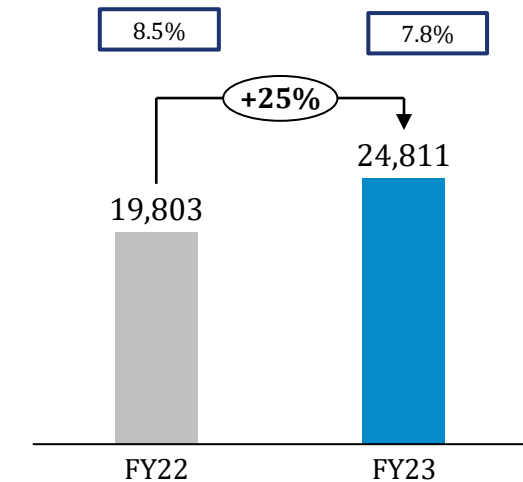

*Excluding Other Income ; Note: Rounded off to the nearest whole number

... coupled with increasing volumes



Volume (tons)

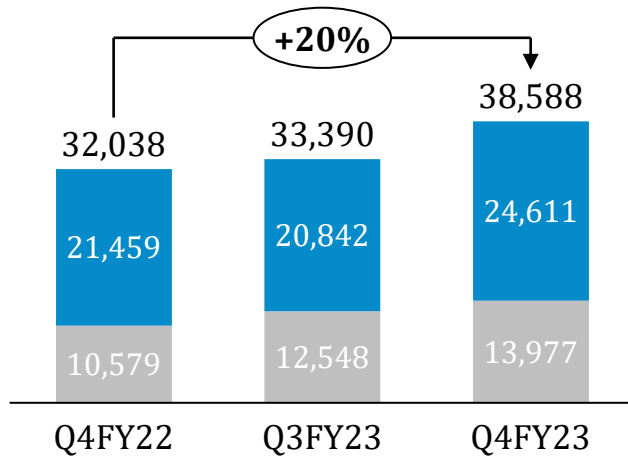

Realisation (Rs. Lac/ (ton))

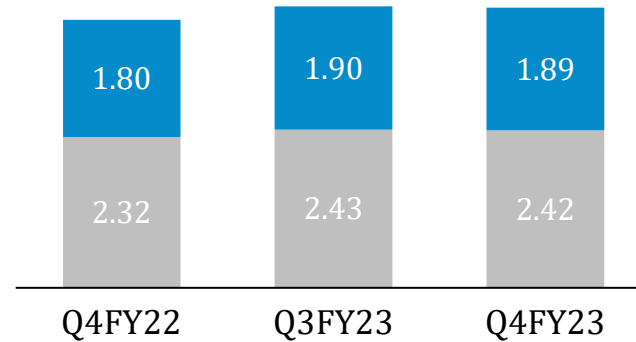

Volume (tons)

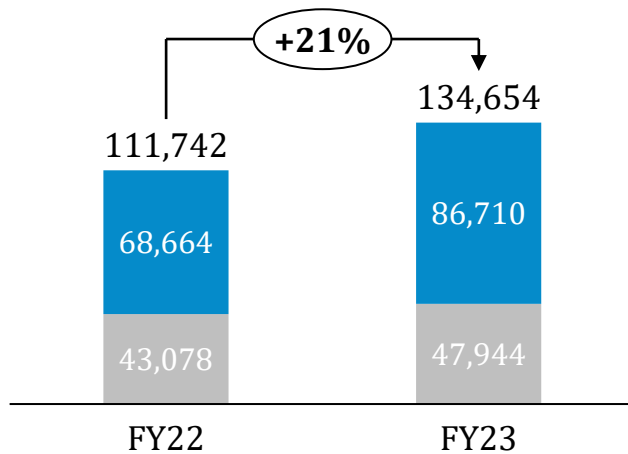

Realisation (Rs. Lac/ (ton))

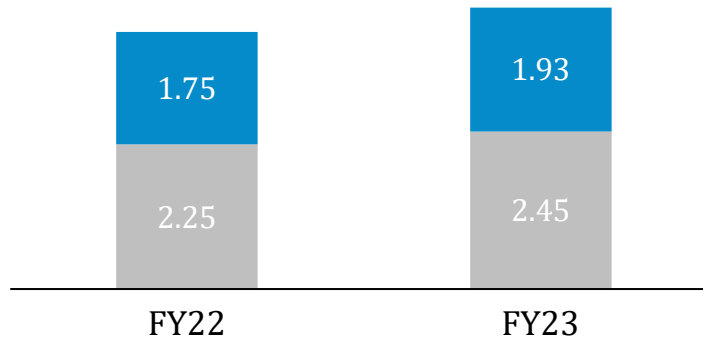

■ Domestic Markets* ■ Export Markets**

Total Revenue Breakup (Rs. Lakhs.)

Particulars	Q4FY23	Q4FY22	YoY	Q3FY23	QoQ
Domestic Markets	49,037	41,758	17.4%	41,911	17.0%
Export Markets	33,811	26,169	29.2%	32,691	3.4%
Other Income	170	0	-	81	109.9%
Export Incentive	692	397	74.3%	629	10.0%
Total	83,710	68,324	22.5%	75,312	11.2%

Total Revenue Breakup (Rs. Lakhs.)

Particulars	FY23	FY22	YoY
Domestic Markets	1,74,498	1,24,086	40.6%
Export Markets	1,23,351	1,02,837	19.9%
Other Income	377	161	134.2%
Export Incentive	2,251	1,614	39.5%
Total	3,00,477	2,28,698	31.4%

*Realisation excluding Fabrication sales

** Realisation excluding ocean freight

.... leading to higher utilizations



Particulars	Installed Capacity	Q4FY23		Q3FY23		Q2FY23		Q1FY23		Q4FY22		Q3FY22	
		Production Capacity (MT)	Utilisation (%)*	Production Capacity (MT)	Utilisation (%)*	Production Capacity (MT)	Utilisation (%)*	Production Capacity (MT)	Utilisation (%)*	Production Capacity (MT)	Utilisation (%)*	Production Capacity (MT)	Utilisation (%)*
Ring Rolling	24,000	8,047	134%	7,390	123%	7,042	117%	7,018	117%	6,841	114%	6,918	115%
Forgings	46,000	12,655	110%	12,810	111%	11,732	102%	10,963	95%	12,104	105%	10,766	94%
Press	117,100	27,660	94%	19,880	68%	19,696	67%	18,489	63%	19,038	65%	16,473	56%
Total Capacity	187,100	48,362	103%	40,080	86%	38,470	82%	36,470	78%	37,983	81%	34,157	73%

*Utilization (%) has been calculated on installed capacity on Annualized basis

... with improving key ratios



Gross Margin (%)

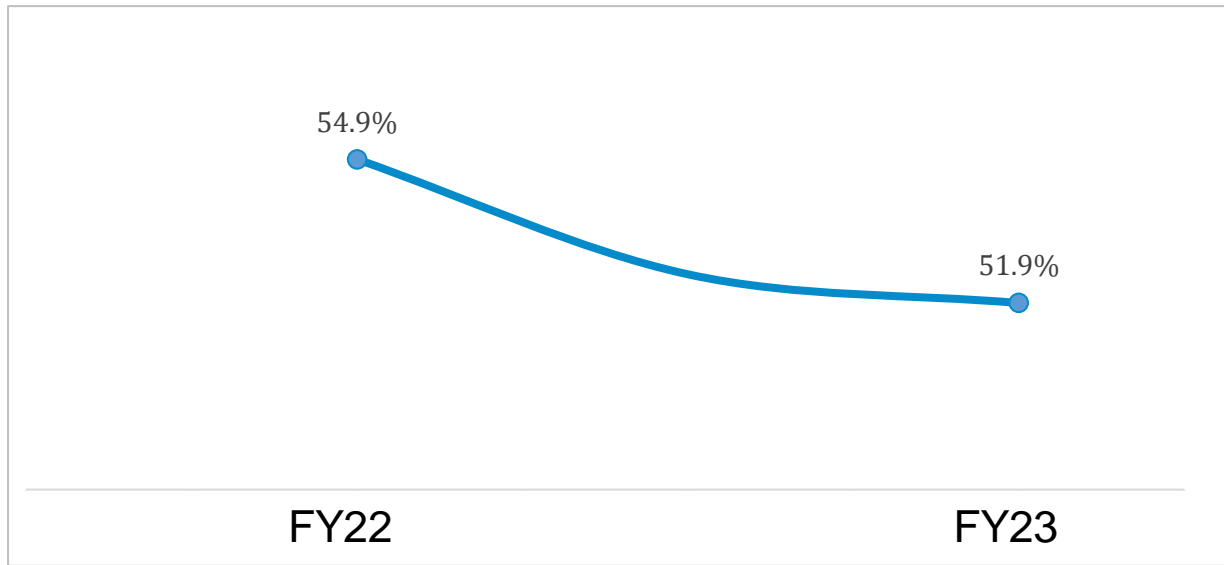

EBIDTA Margin (%)

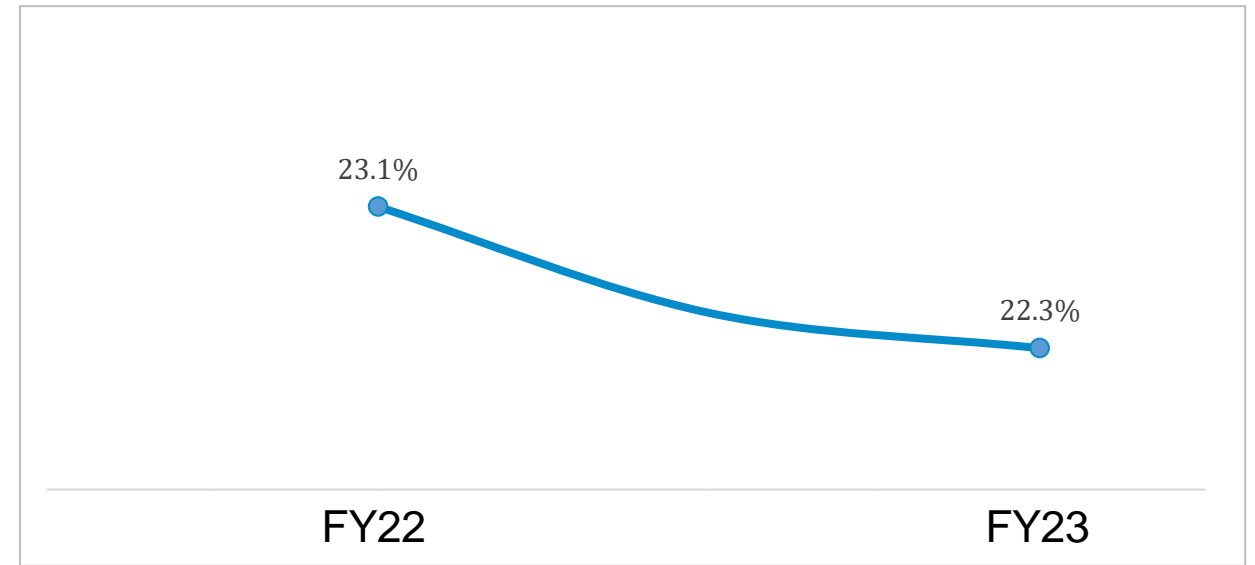

PBT Margin (%)

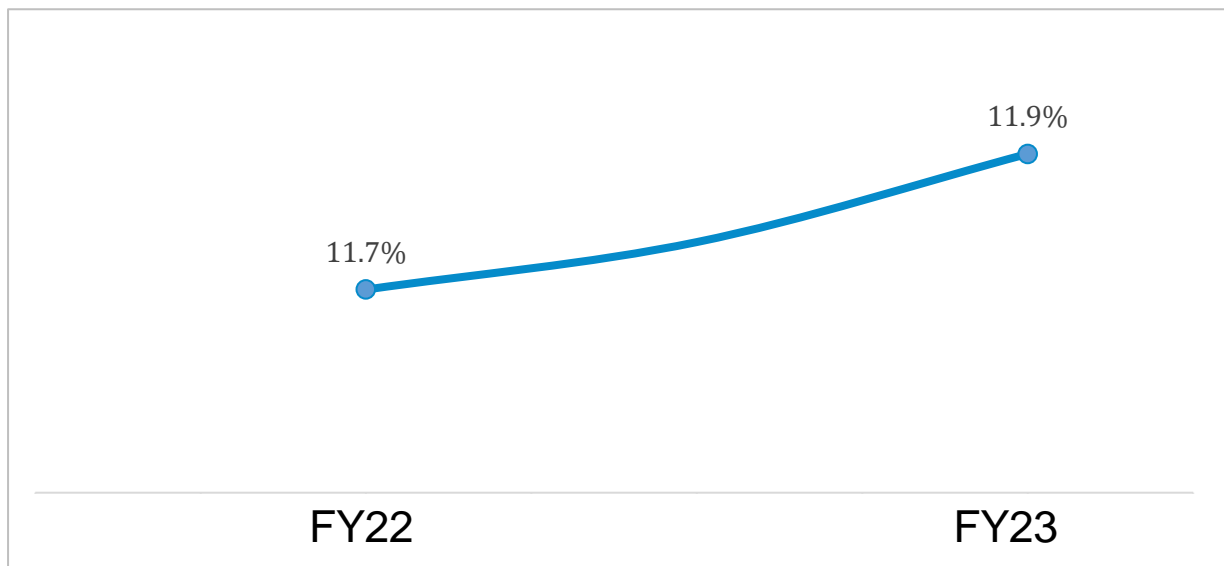

PAT Margin (%)

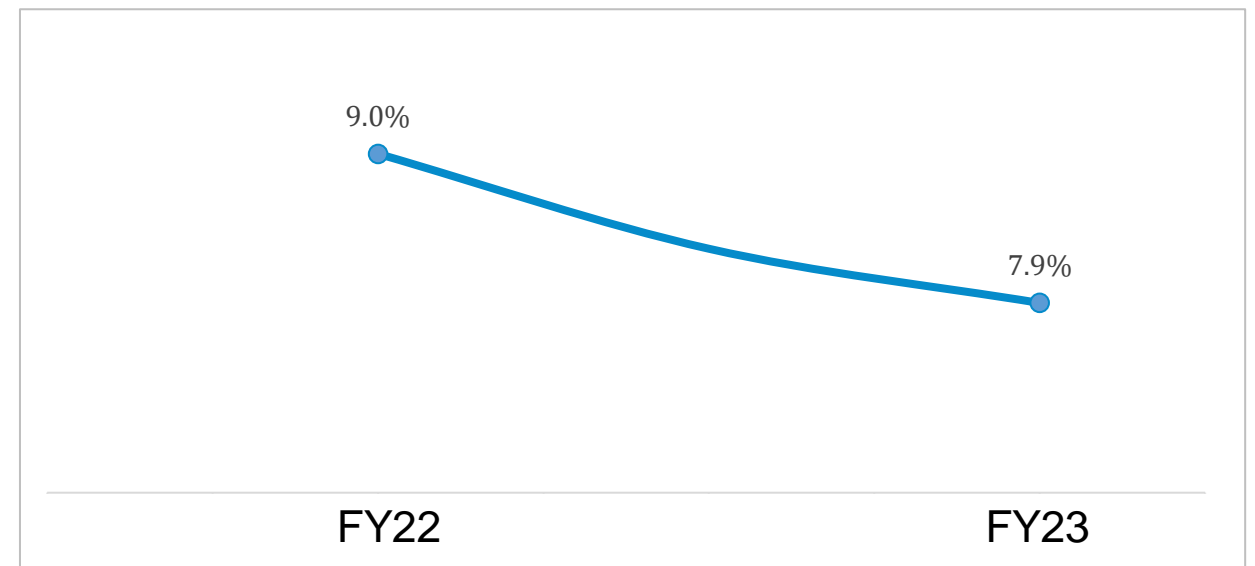

... with improving key ratios

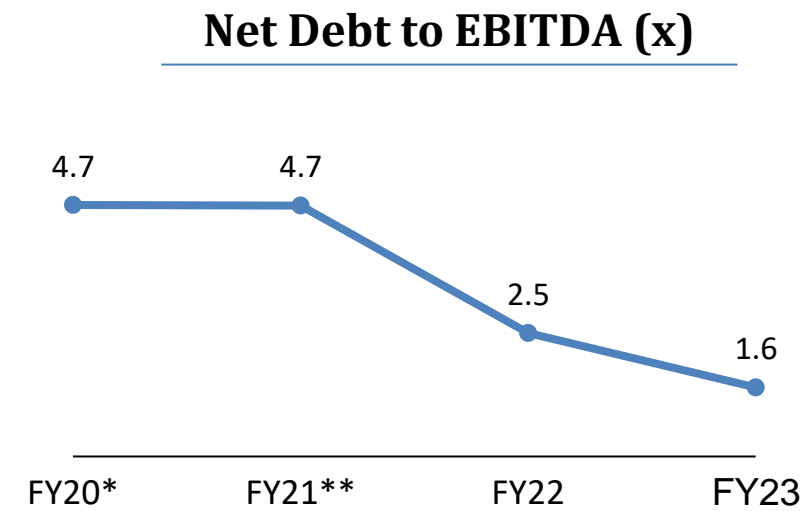
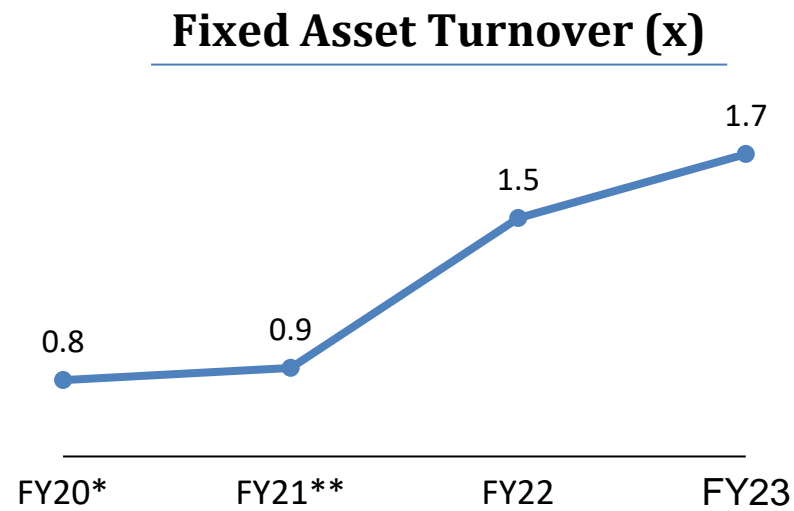
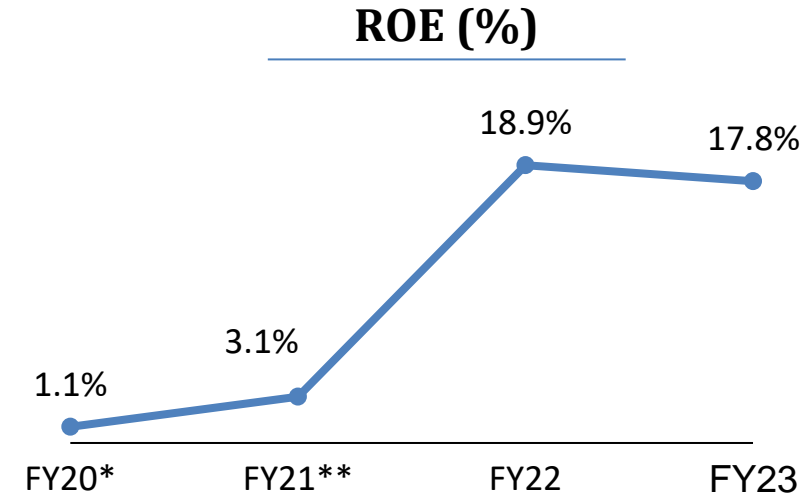
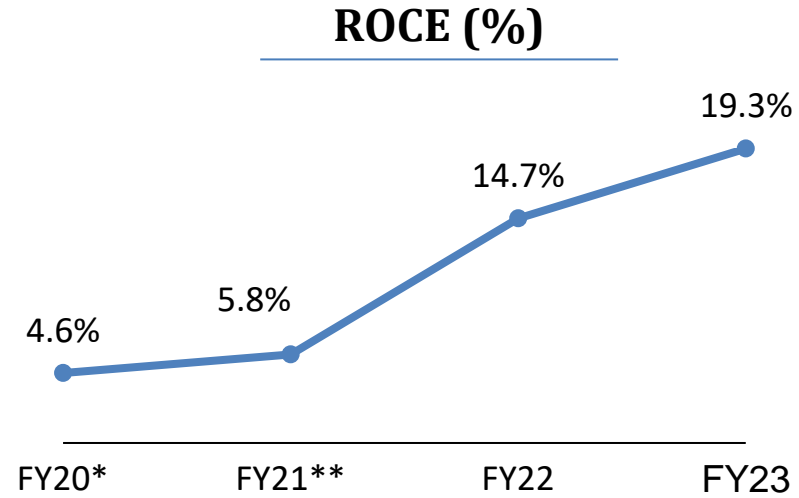

ROCE- EBIT Less Other Income / (Net Debt + Equity); Net Debt to EBITDA- Net Debt/ EBITDA; FATR- Revenue / Fixed Assets (Net); *- FY20 Performance impacted due to economic slowdown leading to sluggish demand for CVs; ** - FY21 Performance impacted due to COVID-19 induced lockdown

Diversified revenues across segments & geographies



By Geography

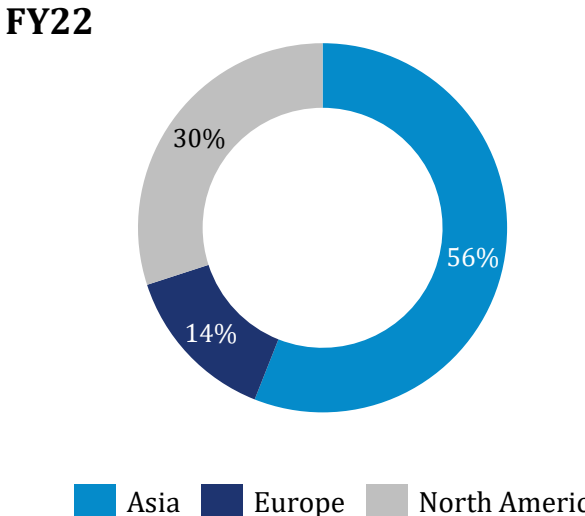
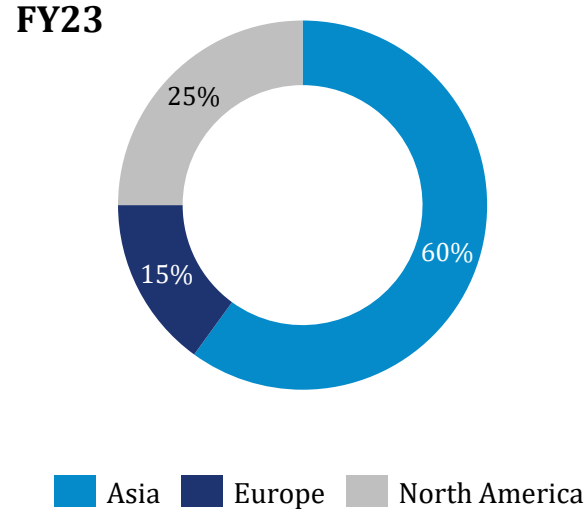

By Segment

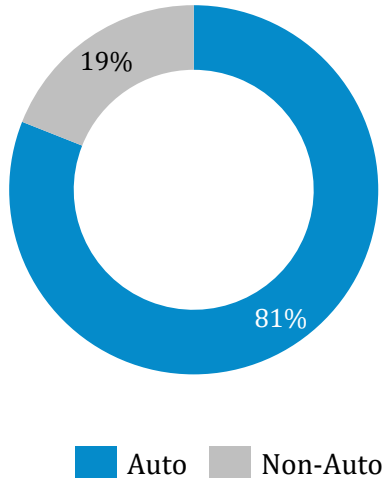
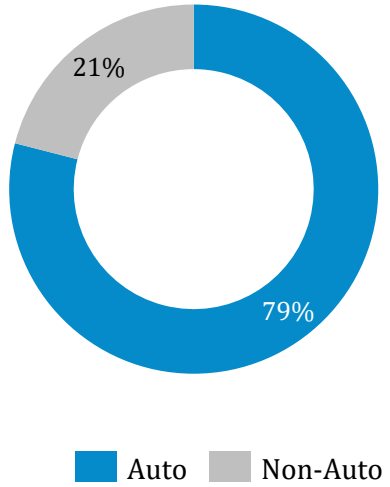

By Industry

	FY23	9MFY23	FY22
Automobiles	78.6%	79.3%	81.1%
Railways	2.9%	2.8%	1.7%
Mining, Earth Moving, Farm & Gen. Engg	8.4%	8.0%	7.6%
Oil & Gas	1.9%	1.6%	0.9%
Others	8.2%	8.3%	8.7%

A decorative background pattern of light gray triangles arranged in a repeating geometric lattice, fading out towards the right side of the slide.

Way Forward

Multiple vectors to accentuate growth and increase profit

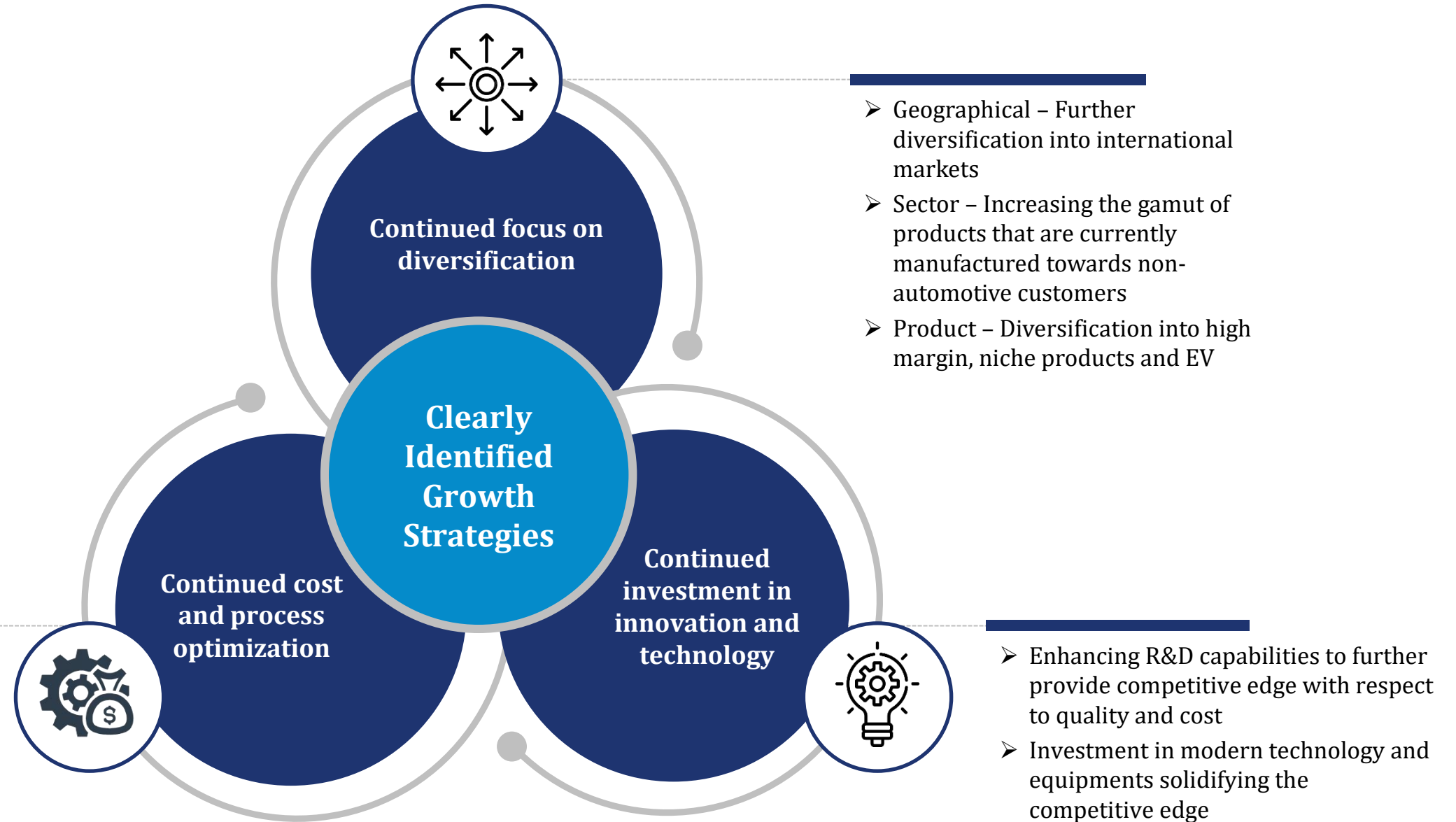

Well positioned to capture future growth



- The forging capacity of the company will be augmented by 56,300 Tons by addition of warm forging press, upset forgings, 6000T press line
- The capacities for the warm forgings and new technology totaling to 18,200T is expected to be commissioned by June 2023 and hot forging capacities of 38,100T shall be commissioned by September 2023
- The Company has sufficient capacity for the next phase of healthy & robust growth.
- Capacity ramp-up along with operating leverage will result in faster improvement in profitability

Installed Capacity

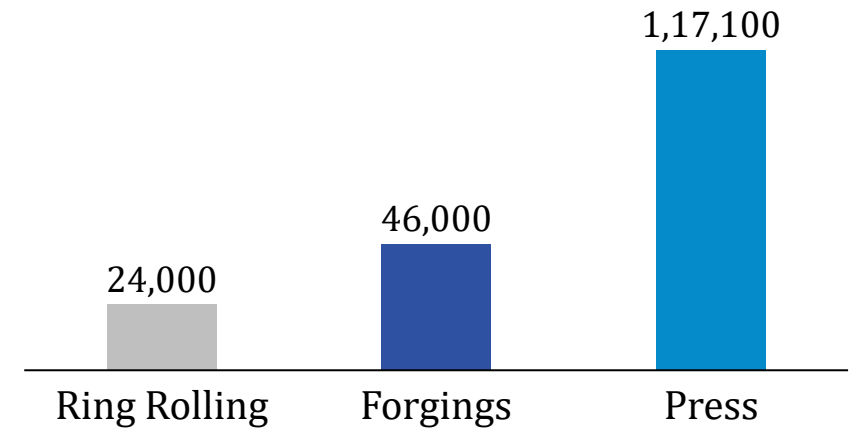

Capacity Utilization*

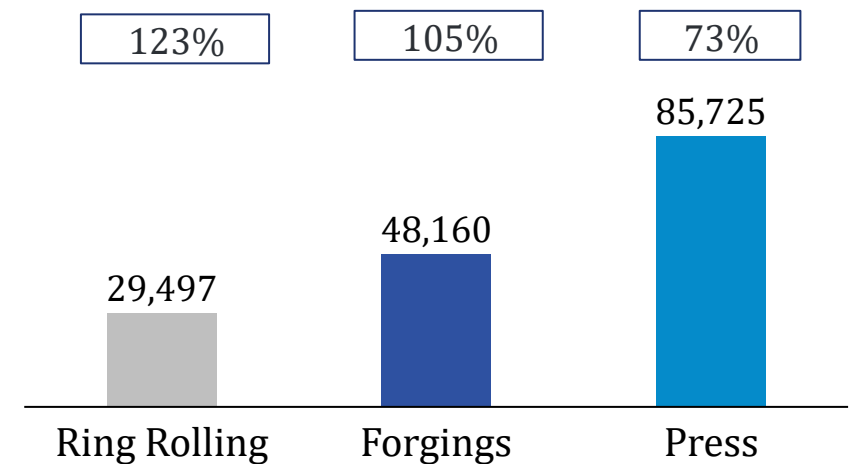

*As on March 31, 2023

Warm Forgings capability



- 5 Station, 2000T fully automated Warm Forging Press from Kurimoto, Japan, with walking beam concept - with capacity of 9,900T
- 2 Station, 630T fully automated screw press from Enomoto, Japan with capacity of 4,500T
- Product Families - Differential Gears & Differential Pinions, Spiders, UJ Cross



Passenger Car & SUV



Commercial Vehicles



Farm Equipment



Tractor



Off-Highway Equipment's

COMBINING FORCES FOR SUCCESS

Rail Wheel Project

- Ramkrishna Forgings & Titagarh Wagons Consortium receives LOA for Manufacturing and Supplying of Forged Wheels for the Indian Railways
- It will establish a manufacturing plant in India for the production of 200,000 forged wheels per annum
- Expected to start operation by end of FY26



EXPANDING THE EV PORTFOLIO

RKFL - TSUYO

Ramkrishna Forgings to acquire upto 51% voting rights in TSUYO Manufacturing”

- Ramkrishna Forgings approved an investment to acquire upto 51% voting rights of TSUYO Manufacturing Private Limited (“TSUYO”)
- It is a leading Mid-Drive BLDC, IPM and AC Induction based motor topologies & a Make-In-India start-up company engaged in powertrain solutions for electric vehicles
- It will aid in expanding its facilities for the manufacture of motors, controllers, E-axles, and differentials
- The Company plans to invest around Rs. 100 Crores over the next 5 (five) years that will generate a turnover of around Rs. 500 Crores by the end of the fifth year



ACQUISITION & EXPANSION

ACIL

- Lenders to ACIL Ltd have approved a resolution plan by Ramkrishna Forgings Limited
- The acquisition will help the company to foray into Tractors and PV segments
- It will be a forward integration which will enable the company to supply machined crankshafts, camshafts for tractors, PV, HCV, LCV as well as two wheelers. Besides, the company also manufactures various products which are used in Tractors and PV
- The acquisition will be financed through internal accruals and debt

ACIL LTD.

JMT Auto

- Lenders to JMT Auto, a unit of Amtek Auto group, have approved a resolution plan by Ramkrishna Forgings Limited
- The acquisition will help the company grow in terms of diversification & market reach as JMT Auto has significant expertise in the auto sector with capabilities in heat treatment and gear and in manufacturing a variety of components for the Oil and Gas industry
- The acquisition plan had been duly approved by 84.61% Committee of Creditors, subject to approval of NCLT Delhi
- The acquisition will be financed through internal accruals and debt
- They have 6 plants in Jamshedpur & 2 plants in Dharwad in western India

JMT AUTO LTD.
An Amtek Group Company



North America

Europe

India/ASIA Pacific

India / Asia Pacific

4 Customer

✓ 7 Programs

□ 4 Programs

Europe

2 Customer

□ 3 Programs

North America

1 Customer

✓ 5 Programs

□ 4 Programs

✓ Programs in Serial Productions

□ Programs in Order book

□ Swedish OEM awards business worth 15 million Euros for component to their EV truck for European Market to commence their development & supplies till 2030 for the awarded business.

Disciplined capital allocation priorities



₹ in Lakhs

Particulars	Mar'23	Mar'22
Gross Debt	1,24,100*	1,57,740*
Net Debt	1,09,367	1,33,632

*Includes customer Bill Discounting of Rs 154 crores for FY 21-22 and Rs 105 crores for FY22-23

01

The Company expect to achieve a healthy revenue growth in the future period

The repayment of debt and payment of dividend will be commensurate with increased cash flow in line with the above growth.

02

A decorative background pattern of light gray triangles arranged in a repeating geometric grid, fading out towards the right side of the slide.

Financial Performance

Income Statement



Particulate (₹ in lakhs)	FY21	FY22	FY23
Revenue from Operations	1,28,838	2,28,537	3,00,100
Cost of Material Consumed	64,083	1,21,423	1,60,368
Change in Inventories of Finished goods & Work in Progress	157	-18,345	-15,994
Cost of services	-	-	-
Purchases of stock-in-trade	-	-	-
Total Raw Material	64,240	1,03,077	1,44,374
Gross Profit	64,597	1,25,459	1,55,725
Gross Profit Margin (%)	50.1%	54.9%	51.9%
Employee Expenses	9,037	12,028	14,431
Power and fuel	9,354	15,240	18,792
Other Expenses	23,214	45,493	55,683
EBITDA	22,993	52,697	66,819
EBITDA Margin (%)	17.9%	23.1%	22.3%
Other Income	461	161	377
Depreciation	11,628	16,906	20,135
EBIT	11,826	35,952	47,061
EBIT Margin (%)	9.2%	15.7%	15.7%
Finance Cost	7,678	9,335	11,496
Profit before Tax	4,148	26,617	35,565
Profit before Tax(%)	3.2%	11.6%	11.9%
Tax	1,352	5,967	12,005
Profit After Tax	2,796	20,650	23,559
PAT Margin (%)	2.2%	9.0%	7.9%
EPS (As per Profit after Tax)	1.74	12.91	14.73

Balance Sheet



Equity & Liabilities (₹ in lakhs)	FY21	FY22	FY23
Equity			
Equity Share Capital	3,193	3,198	3,198
Other Equity	85,804	1,06,210	1,29,295
Total Equity	88,997	1,09,408	1,32,492
Non-Current Liabilities			
Financial Liabilities			
Borrowings	66,360	85,945	75,092
Lease Liabilities	378	2,280	2,054
Deferred Tax Liabilities	6,588	7,927	11,716
Provisions	-	-	-
Other Non Current Liabilities	1,699	1,568	4,361
Total Non-Current Liabilities	75,026	97,720	93,223
Current Liabilities			
Financial Liabilities			
Borrowings	54,160	71,794	49,008
Lease Liabilities	22	429	550
Trade Payables	42,916	57,457	76,614
Other Current Financial Liabilities	4,886	3,594	5,888
Other current liabilities	1,228	2,401	2,585
Provisions	520	595	876
Current Tax Liabilities (net)	170	213	1,823
Total Current Liabilities	1,03,901	1,36,484	1,37,343
Total Equity & Liabilities	2,67,923	3,43,612	3,63,059

Assets (₹ in lakhs)	FY21	FY22	FY23
Non - Current Assets			
Property, plant and equipment	1,22,183	1,43,394	1,65,447
Capital work-in-progress	27,202	12,509	8,508
Right of use assets	1,009	3,058	2,961
Goodwill on Amalgamation	-	-	-
Intangible assets	79	113	81
Financial Assets			
Investments	1,938	1,938	1,939
Trade Receivables	-	-	-
Loans	170	222	141
Other Financial Assets	1,270	1,324	1,945
Non-current Tax Assets	250	250	250
Deferred Tax Assets	-	-	-
Other non-current assets	1,485	5,316	7,208
Total Non - Current Assets	1,55,585	1,68,123	1,88,479
Current Assets			
Inventories	42,994	68,267	86,852
Financial Assets			
Investments	-	5,500	-
Trade receivables	55,993	87,781	72,536
Cash and cash equivalents	6,659	3,102	4,094
Bank balances other than (iii) above	22	134	153
Loans	12	112	102
Other current financial assets	1,082	3,488	1,456
Other current assets	5,563	7,089	9,373
Current Tax Assets	14	14	14
Total Current Assets	1,12,339	1,75,489	1,74,581
TOTAL ASSETS	2,67,923	3,43,612	3,63,059

Cash Flow



Particulate (₹ in lakhs)	FY21	FY22	FY23
Cash Flow from Operating Activities			
Profit before Tax	4,148	26,617	35,565
Adjustment for Non-Operating Items	18,453	23,592	26,758
Operating Profit before Working Capital Changes	22,601	50,210	62,322
Changes in Working Capital	-9,394	-41,746	22,177
Cash Generated from Operations	13,207	8,464	84,499
Less: Direct Taxes paid	-557	-4,556	-6,724
Net Cash from Operating Activities	12,650	3,908	77,776
Cash Flow from Investing Activities	-22,622	-35,348	-29,727
Cash Flow from Financing Activities	16,405	27,884	-47,057
Net increase/ (decrease) in Cash & Cash equivalent	6,432	-3,556	992
Add: Cash and cash equivalents as at 1st April	226	6,659	3,102
Cash and cash equivalents as at 31st March	6,659	3,102	4,094

A decorative background pattern of light gray triangles arranged in a repeating geometric pattern, fading out towards the right.

Our Commitment

<p>The vision is to commit to preserving and protecting the environment across its operations</p>	<p>Environmental Consciousness We will take sustained efforts towards creating a healthy planet by reducing our carbon footage, mitigating climate change and optimizing our business operations</p>	
<p>The vision is to be the employer and partner of choice for our employees and suppliers and help the local communities thrive</p>	<p>Valuable Partnerships Develop relationships with our suppliers through assessments, collaborations, capacity building and develop a resilient supply chain</p>	
	<p>Rewarding Workplace We value a diverse workforce and work towards creating a healthy workplace where talent is developed, recognized and rewarded</p>	
	<p>Empowered Communities Ensuring positive relationships with our communities and contributing to their welfare by reducing inequality, promoting education, health and gender equality</p>	
<p>The vision is to operate ethically and responsibly with transparency</p>	<p>Robust Governance Following an effective governance model and focus on business integrity to achieve business & sustainability goals.</p>	



Clean Energy

Our Commitment: To be powered by 50% green energy by 2028

Keeping in line with India's commitment to sourcing half of its energy from non-fossil fuel sources by 2030, we at RKFL have adopted various energy conservation techniques and clean energy practices in our daily business activities

We have finalized Prozeal Infra Engineering Private Limited as our vendor to install a 7.82 MW solar power plant in our Jamshedpur Plant



Energy Optimisation

Our Commitment: To be Carbon Neutral by 2050

To improve our energy efficiency measure, we conducted a detailed energy audit across all our manufacturing units in January 2023. The study has helped us in identifying energy hotspots, leakage and improvement areas

Moreover, we are also conducting GHG emission study including Scope 3 emission to develop a Carbon Neutral Strategy for our business



Product Stewardship

Considering the upcoming regulations such as Carbon Border Adjustment Mechanism (CBAM), **we are conducting a Life Cycle Assessment for three of our products - Front Axle Beam, Crown Wheel and Knuckles**

The study will help us in identifying and preparing a plan to reduce the overall environmental impact of these products along with their manufacturing cost

ROAD AHEAD – Q1 FY24

- Developing a carbon-neutral strategy in line with our net-zero commitment
- Integrating robust and adaptive strategies to meet our clean energy commitment
- Working towards embedding sustainability across the life-cycle of our products



Talent Development

Our Commitment: Train 100% of our employees on ESG by 2023 and on Human Rights by 2025

In March 2023, we conducted capacity-building workshops at our headquarters in Kolkata and manufacturing units in Jamshedpur on ESG Awareness, Human Rights and Diversity, Equity & Inclusion.

These workshops will increase employee awareness across RKFL's commitments, initiatives and policies related to ESG. This will also help us to create a robust workforce to achieve our ESG commitments.



Supply Chain Management

Our Commitment: Conduct 100% supplier audits by 2024

SEBI recently announced that ESG disclosure & assurance will be introduced for the value chain of the top 250 listed entities but the numbers will increase eventually. Thus, it is necessary for us to manage our ESG-related risks by increasing traceability and transparency in our supplier activity.

We have decided to integrate environmental, social & governance (ESG) factors across our supply chain practices. This will help us to improve our resource efficiency by ensuring the responsible deployment of natural resources & proper disposal of harmful materials.



Community Empowerment

Our Commitment: Increase Employee Volunteering to 55% by 2030

Community Development is at the core of our heart. To understand the needs of the community and respond in an effective manner we have set up a dedicated team of professionals.

In order to support the Central Government's efforts for a clean and green environment, RKFL has partnered with Newage Clean Solutions to set up 60 bins across Jamshedpur.

ROAD AHEAD – Q1 FY24

- Capacity Building Workshop on Employee Code of Conduct & Supplier Quality Manual
- Integrating ESG Risk Framework in our Supplier Selection Process through vendor categorisation & audits
- Enhance our community engagement activities by fostering employee volunteering



Policy Structure

Our Commitment: Build effective policies and strengthen our outreach

In an effort to build transparency and strong corporate culture, we have refreshed our existing policies and introduced new policies. These policies aim to establish the code of conduct, outline employee responsibilities as well as provide guidelines for interaction with stakeholders.

We have introduced Human Rights Policy, Diversity, Equity & Inclusion Policy and Stakeholder Engagement Approach in our policy structure.

ROAD AHEAD – Q1 FY24

- Introduce Customer Grievance Redressal Policy & Business Continuity Policy
- Refresh CSR Policy, Code of Conduct, Supplier Quality Manual, POSH Policy & Whistle Blower Policy
- Set up systems to review policies periodically in the future

This presentation and the accompanying slides (the “Presentation”), which have been prepared by Ramkrishna Forgings Limited (the “Company”), have been prepared solely for information purposes and do not constitute any offer, recommendation or invitation to purchase or subscribe for any securities, and shall not form the basis or be relied on in connection with any contract or binding commitment whatsoever. No offering of securities of the Company will be made except by means of a statutory offering document containing detailed information about the Company.

This Presentation has been prepared by the Company based on information and data which the Company considers reliable, but the Company makes no representation or warranty, express or implied, whatsoever, and no reliance shall be placed on the truth, accuracy, completeness, fairness and reasonableness of the contents of this Presentation. This Presentation may not be all inclusive and may not contain all of the information that you may consider material. Any liability in respect of the contents of, or any omission from, this Presentation is expressly excluded.

Certain matters discussed in this Presentation may contain statements regarding the Company’s market opportunity and business prospects that are individually and collectively forward-looking statements. Such forward-looking statements are not guarantees of future performance and are subject to known and unknown risks, uncertainties and assumptions that are difficult to predict. These risks and uncertainties include, but are not limited to, the performance of the Indian economy and of the economies of various international markets, the performance of the industry in India and world-wide, competition, the Company’s ability to successfully implement its strategy, the Company's future levels of growth and expansion, technological implementation, changes and advancements, changes in revenue, income or cashflows, the Company's market preferences and its exposure to market risks, as well as other risks. The Company's actual results, levels of activity, performance or achievements could differ materially and adversely from results expressed in or implied by this Presentation. The Company assumes no obligation to update any forward-looking information contained in this Presentation. Any forward-looking statements and projections made by third parties included in this Presentation are not adopted by the Company and the Company is not responsible for such third-party statements and projections.

All Maps used in the Presentation are not to scale. All data, information and maps are provided "as is" without warranty or any representation of accuracy, timeliness or completeness.



COMPANY :



Ramkrishna Forgings Limited

CIN : L74210WB1981PLC034281

Mr. Lalit Kumar Khetan (Whole Time Director & CFO)

E: lalit.khetan@ramkrishnaforgings.com

www.ramkrishnaforgings.com

INVESTOR RELATIONS ADVISORS :



Orient Capital (a division of Link Group)

Mr. Nikunj Jain

+91 9769060608

nikunj.jain@linkintime.co.in

Mr. Amar Yardi

+91 7045121239

amar.yardi@linkintime.co.in