

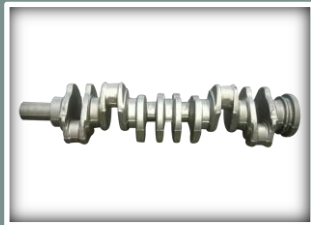

Ramkrishna Forgings Limited

Corporate Presentation – September 2023

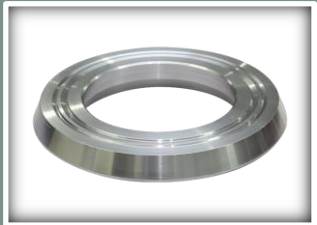



# About Ramkrishna Forgings



## MR. NARESH JALAN



Our company is committed to stringent capital allocation practices, aimed at improving return ratios and generating higher shareholder value. We prioritize sustainable growth and profitability by carefully evaluating investment opportunities and integrating sustainability principles into our operations. Through automation and artificial intelligence, we are in process of enhancing operational efficiency, increase productivity, and address evolving customer demands. Our focus on improving return on capital employed (ROCE) and return on equity (ROE) drives financial performance.

We remain vigilant and closely monitor macroeconomic risks, proactively mitigating them by prioritizing customer relationships and delivering excellent service. We are dedicated to proactively positioning ourselves for future growth and increasing our market share. Our strategic focus revolves around preparing for improved market conditions, ensuring that we are well-prepared to seize opportunities. This includes our efforts to enhance our capacity, aligning our actions with our long-term vision to thrive and succeed in the future.

Additionally, we are actively working towards reducing our debt burden, targeting a Debt to EBITDA level of 1:1 by FY25. This disciplined approach will strengthen our financial position, reduce risks, and provide us with flexibility to pursue growth opportunities.

# Key Highlights



Manufacturer and supplier of a variety of auto and non-auto components



Global presence with footprints in North America and Europe



2nd largest forging player in India with over 40 years of experience



Promoter possessing multi-decade forgings industry experience



Continued focus on diversification with foray into EV components



Longstanding relationship with marquee customers

# One of the largest forging players in India

## Vision, Mission & Core Values



### Vision

To Create Value for all business partners, shareholders and customers in all areas of business Ramkrishna Forgings Limited is associated while demonstrating world-class standards of Sustainability, Social Responsibility and Governance



### Mission

To be the most preferred supplier of forged, rolled, machined, fabricated and cast products for all end use industries like Railways, Automotive, Earth Moving, Mining, Farm Equipment, Oil & Gas and General Engineering globally by supplying products meeting highest quality standards at highly competitive costs



### Core Values

Customer centric approach  
Continual improvements in systems  
Commitment to human development



# ... with over four decades of unique capabilities

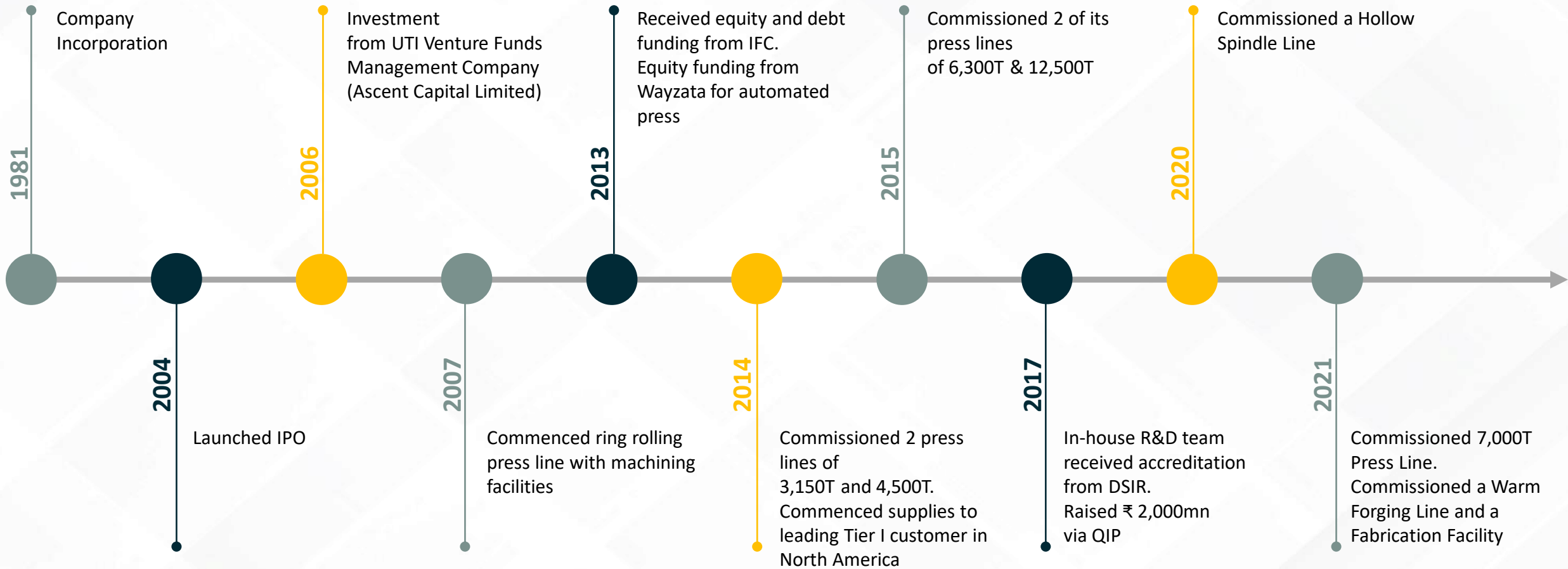

# ... at strategic locations giving us competitive edge



## Proximity to automobile manufacturing hubs & key suppliers

- RKFL's facilities in eastern India are located in close proximity to automobile manufacturing hubs and key suppliers of raw material
  - Less chance of supply interruptions
  - Lower logistics cost
  - Reduced working capital requirements

## All facilities located within the same region

- Better integration resulting in efficient processes
- Improved coordination
- Overall cost savings, including administrative costs

## Proximity to key export hubs

- Reduces logistics cost
  - 302km\* to Kolkata port
  - 270km\* to Haldia port

## Availability of labor

- Eastern region is the industrial center of India
- Low cost labor easily available
- Lower dependency on migrant laborers

# ... demonstrating superior performance\*



23

Countries Served



1,87,100T

Installed Capacity

Increased to **2,10,900T**  
with effect from 18th July 2023



87%

Capacity Utilisation



1,34,654

Sales Volume

↑ 21% YoY



₹ 3,001 cr

Revenue

↑ 31% YoY



100%

Dividend#



3%

Total Turnover  
from EV



₹ 668 cr

EBITDA

↑ 27% YoY



22.3%

EBITDA Margin



19.3%

ROCE



17.8%

ROE



1.6x

Net Debt to EBITDA

\*As on 31st March 2023 on standalone financials; #Dividend as % of Face Value of Rs 2 each

# ... clear focus on de-risking business

Company has a clear focus towards de-risking the business by reducing dependency on single product or single client

**New verticals**

**New product categories**

**New Geographies**

**New customers**









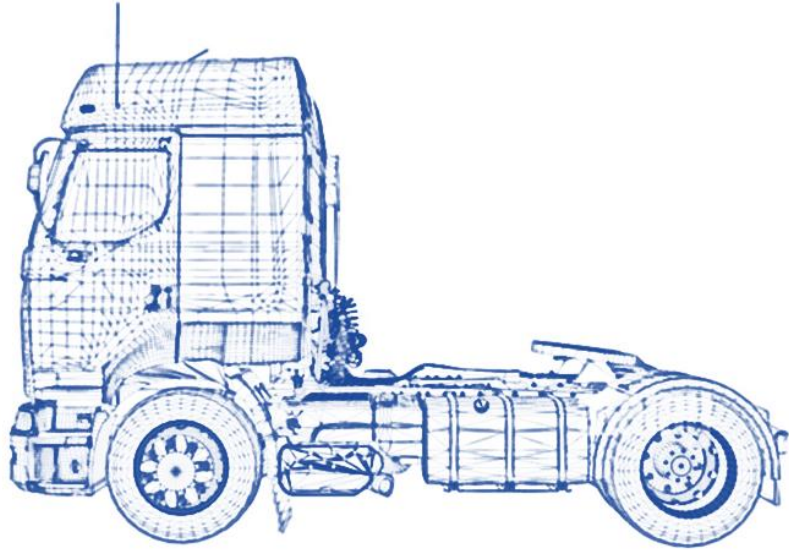















**Increased machining**

**New fabrication products**

	2019	2023
<b>De-risking Business Strategies</b>		
New verticals	2	4
New product categories	35	51
New Geographies	15	23
New customers	153	218
Increased machining	59%	74%
New fabrication products	0	7

# ... offering diversified products



<h2>Front Axle &amp; Steering</h2>	 I Beam	 Knuckle	 Steering Arm	 Tie Rod Arm	 Sector Shaft	 Front Hub		
<h2>Engine</h2>	 Crankshaft	 Camshaft	 Connecting Rod	 Piston	 Pitman Arm			
<h2>Suspension &amp; Chassis</h2>	 BC Lever Assembly		 Mounting Brackets	 Yokes	 UJ Cross			
<h2>Transmission</h2>	 Transmission Gears			 Transmission Shafts Gears				
<h2>Rear Axle</h2>	 Crown Wheel	 Pinion	 Differential Case	 Differential Case Cover	 Spindle	 Rear Axle Shaft	 Spider	 Gears

# ... offering diversified products

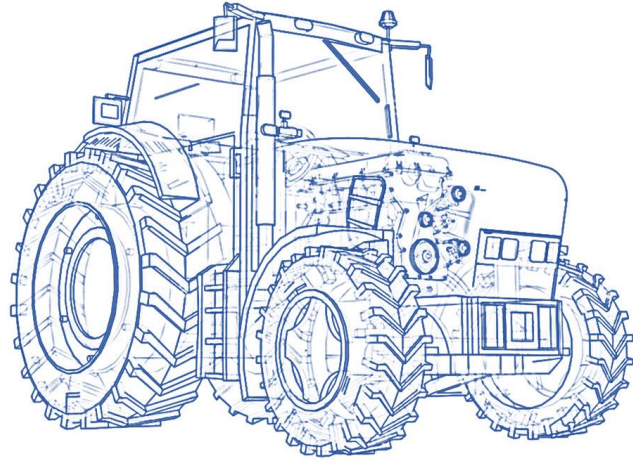

## Tractors & Tillers



Crown Wheel & Pinion



1,2,3 & 4 Cyl Forged Crankshafts



Transmission Shafts & Gears



Rear Axle Shafts

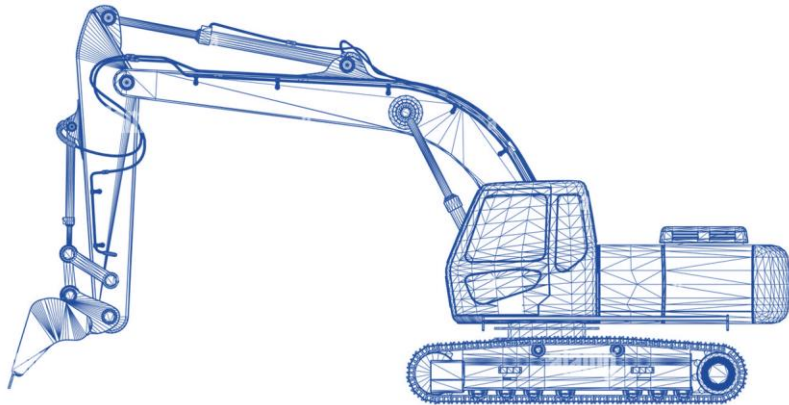

## Earth Moving



Bucket



Backhoe Bucket



Shovel



Track Link



Track Roller



Bucket Tooth



Pivot Pin



Prop Shaft



Bearing Centre

# ... offering diversified products

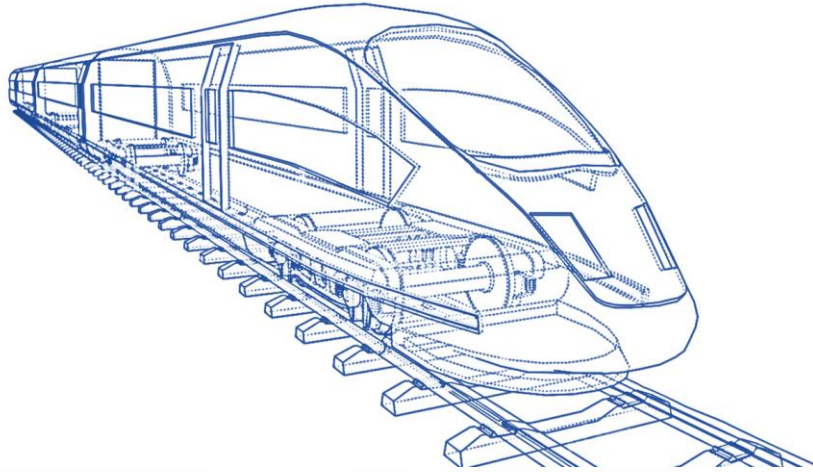

## Railways



Bogie Frame - LHB



Bogie Bolster - LHB



Bogie Frame- Euro Project



Bogie Frame - Kolkata Metro



Fully Assembled Bogie - Vande Bharat

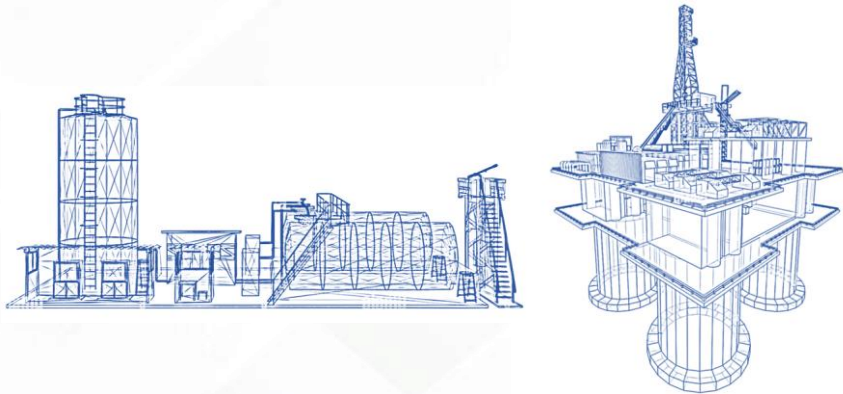

## Energy



Wing Nut



Valve Bonnet



T Bolt Socket Joint



Toothed Crusher Hammer



SUB 3 Inch - Female



Valve Seat- 5 inch



Tee Forging

# ... with growing global footprints



## Headquarters & Manufacturing facilities

- Headquarters – Kolkata  
6 manufacturing facilities
- Jamshedpur – 3
  - Seraikela – Kharswan – 2
  - Howrah – West Bengal – 1



## Sales & support office:

- Detroit, USA
- Sao Paulo, Brazil
- Istanbul, Turkey
- Monterrey, Mexico
- Toluca, Mexico
- Frankfurt, Germany
- Milan, Italy



## Warehousing facility:

- Shelbyville, USA
- Hagerstown, USA
- Indianapolis, USA
- Monterrey, Mexico
- Toluca, Mexico
- Pubela, Mexico
- Westerloo, Belgium

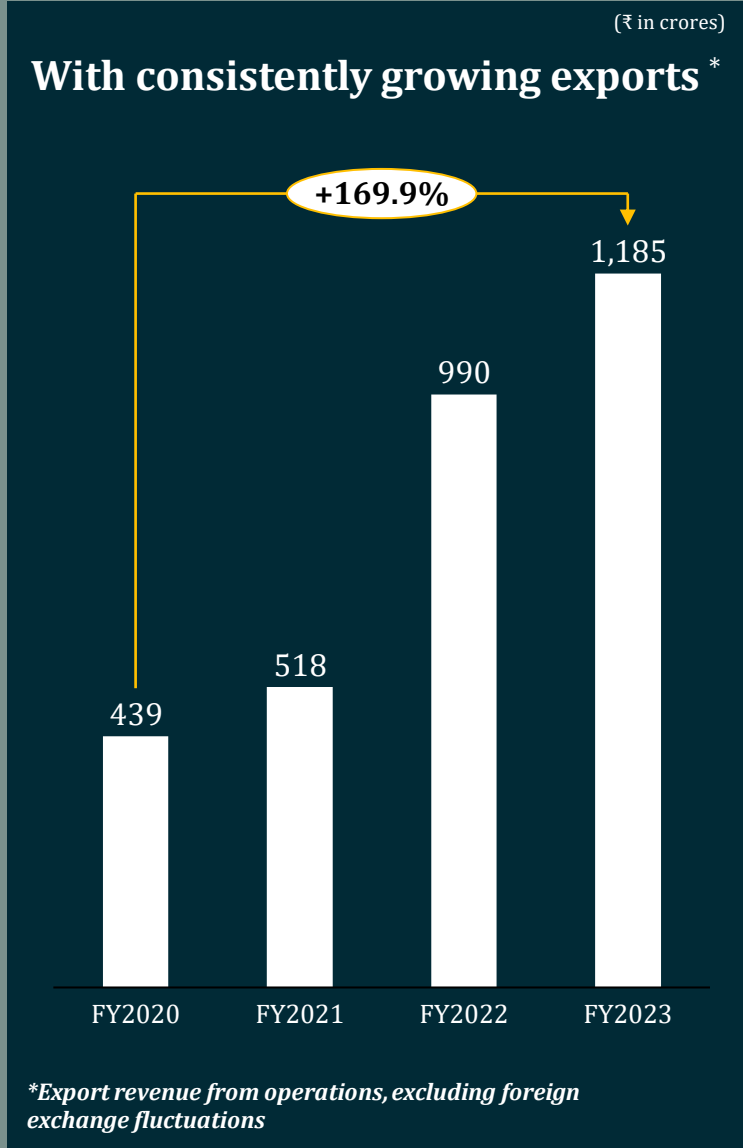

# ...with multiple accreditations & certifications



**ISO 9001:2015**  
QMS



**IATF 16949:2016**  
QMS for Automotive  
Production



**ISO 14001:2015**  
Environmental  
Management



**ISO 45001:2018**  
Occupational Health and  
Safety Management



**ISO/TS 22163:2017**  
Quality & Business  
Management Systems  
for Railways



**EN 15085-2:2020**  
Welding of Railway Vehicles  
And Components





# Financial Prudence



# Diversified revenues across segments & geographies

**Q1FY24**

**By Geography**

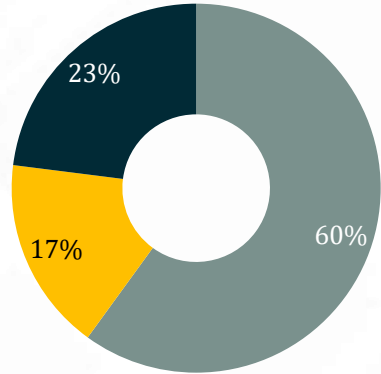

Asia Europe North America

**By Segment**

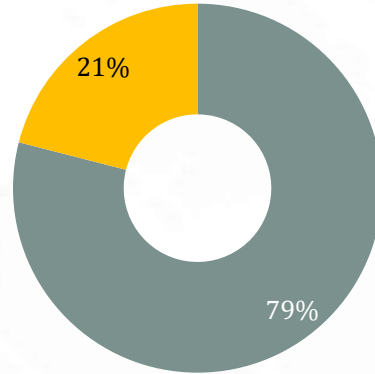

Auto Non-Auto

**FY23**

**By Geography**

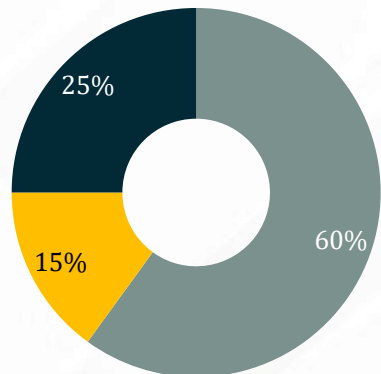

Asia Europe North America

**By Segment**

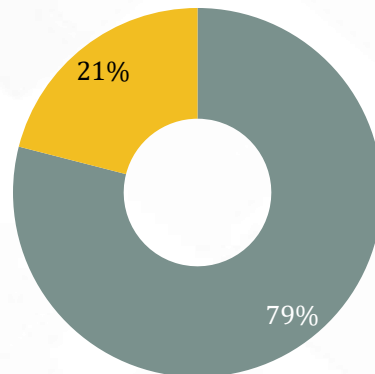

Auto Non-Auto

**By Industry**

	Q1FY24	FY23	Q1FY23
Automobiles	78.8%	78.6%	80.3%
Railways	3.2%	2.9%	2.1%
Mining, Earth Moving, Farm & Gen. Engg	8.5%	8.4%	7.0%
Oil & Gas	1.9%	1.9%	1.9%
Others	7.6%	8.2%	8.7%

Strong growth across both domestic (8% CAGR) and export markets (24% CAGR) from FY19 to FY23

Continued focus on de-risking of geographical revenue by new customer additions globally. Absolute contribution from North America, Latin America, Europe and South East Asia has increased

# ... coupled with increasing volumes

**Volume (tons)**

**Realisation (Rs. Lac/ (ton))**

**Volume (tons)**

**Realisation (Rs. Lac/ (ton))**

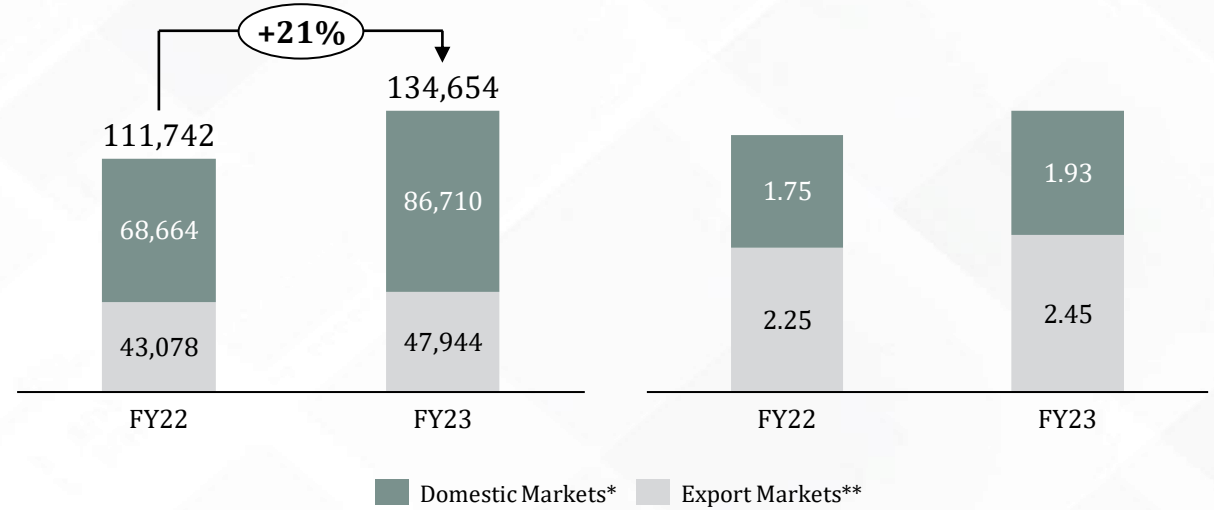
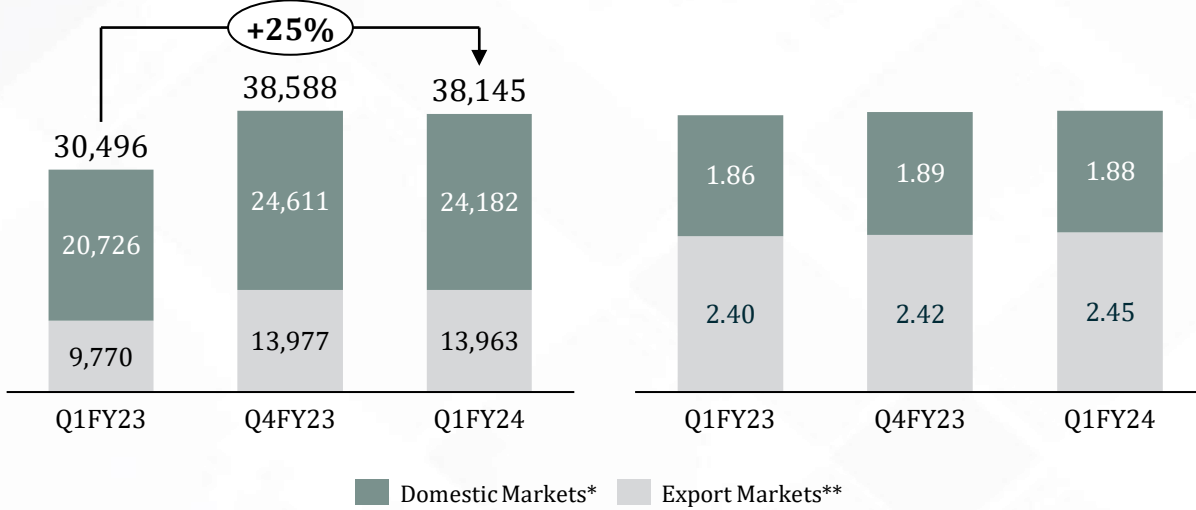

Total Revenue Breakup (Rs. Lakhs.)					
Particulars	Q1FY24	Q1FY23	YoY	Q4FY23	QoQ
Domestic Markets	48,243	39,925	20.8%	49,037	-1.6%
Export Markets	34,564	24,739	39.7%	33,811	2.2%
Other Income & Export Incentive	1,261	477	164.4%	862	46.3%
<b>Total</b>	<b>84,068</b>	<b>65,141</b>	<b>29.1%</b>	<b>83,710</b>	<b>0.4%</b>

Total Revenue Breakup (Rs. Lakhs.)			
Particulars	FY23	FY22	YoY
Domestic Markets	1,74,498	1,24,086	40.6%
Export Markets	1,23,351	1,02,837	19.9%
Other Income & Export Incentive	2,628	1,775	48.1%
<b>Total</b>	<b>3,00,477</b>	<b>2,28,698</b>	<b>31.4%</b>

\*Realisation excluding Fabrication sales

\*\* Realisation excluding ocean freight

# .... leading to higher utilizations



Particulars	Installed Capacity	Q1FY24		Q4FY23		Q1FY23	
		Production Capacity (MT)	Utilisation (%)*	Production Capacity (MT)	Utilisation (%)*	Production Capacity (MT)	Utilisation (%)*
Ring Rolling	24,000	7,617	127%	8,047	134%	7,018	117%
Forgings	46,000	11,944	104%	12,655	110%	10,963	95%
Press	117,100	23,681	81%	27,660	94%	18,489	63%
Total Capacity	187,100	43,242	92%	48,362	103%	36,470	78%

\*Utilization (%) has been calculated on installed capacity on Annualized basis

# Strong key ratios



## ROCE (%)

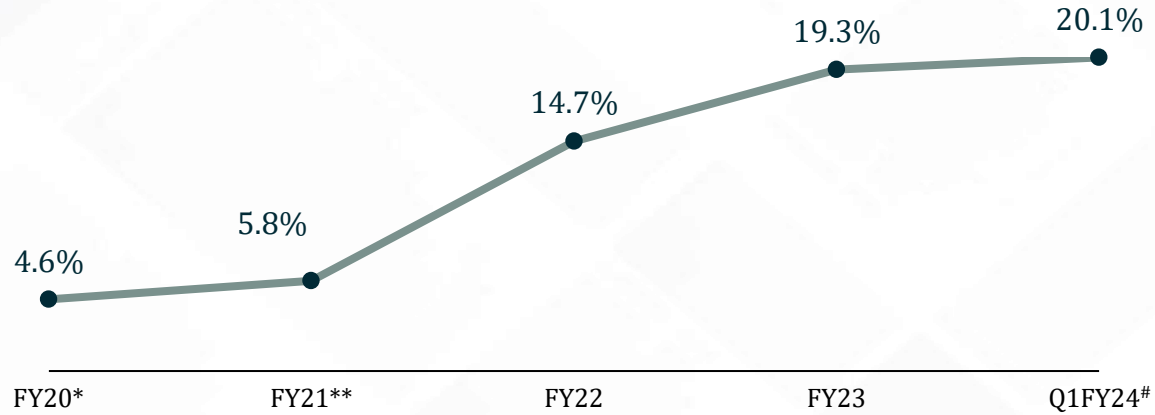

## ROE (%)

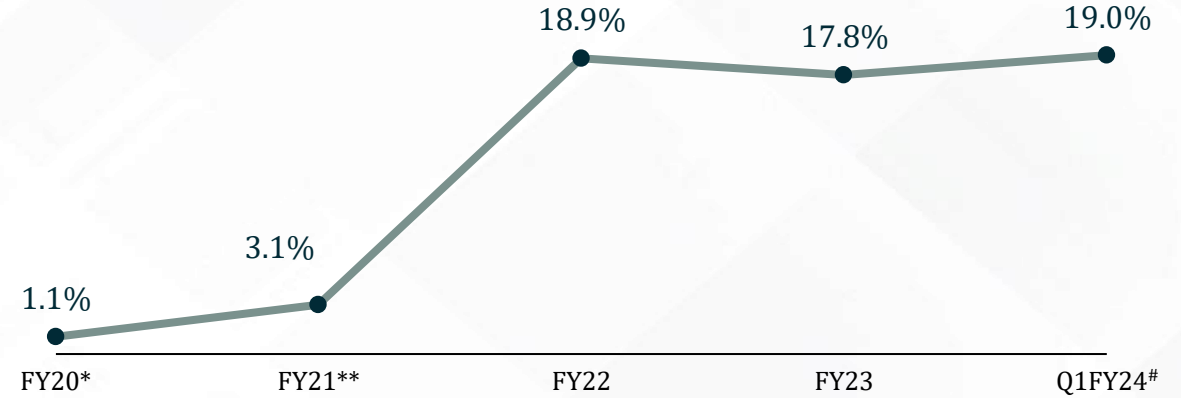

## Fixed Asset Turnover (x)

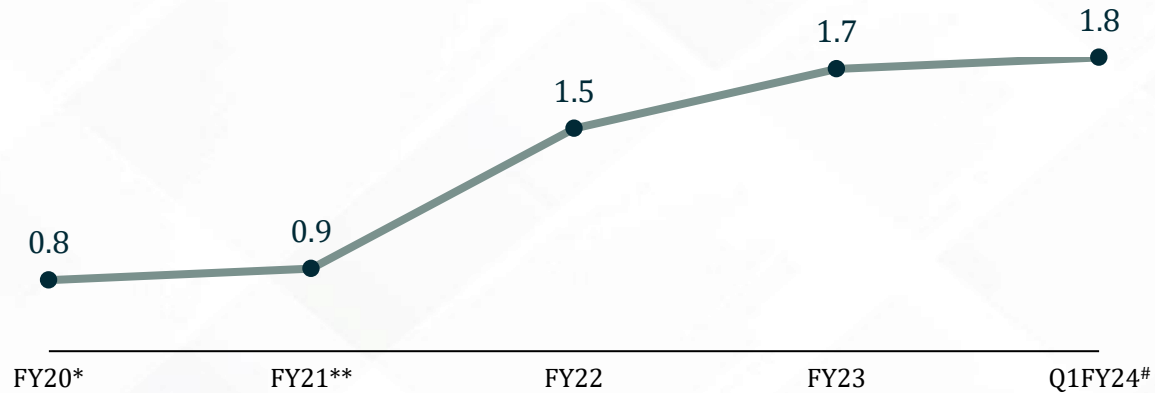

## Net Debt to EBITDA (x)

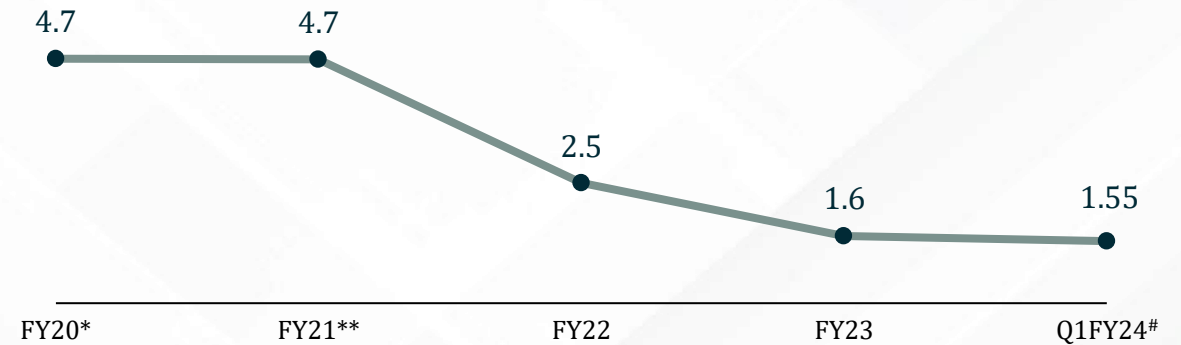

ROCE- EBIT Less Other Income / (Net Debt + Equity); Net Debt to EBITDA- Net Debt/ EBITDA; FATR- Revenue / Fixed Assets (Net); \*- Fy20 Performance impacted due to economic slowdown leading to sluggish demand for CVs; \*\* - FY21 Performance impacted due to COVID-19 induced lockdown; #Q1FY24 numbers are annualized.



# Way Forward



# Multiple vectors to accentuate growth and increase profitability



## CLEARLY IDENTIFIED GROWTH STRATEGIES

01



### Continued focus on De-risking

- Geographical – Further diversification into international markets
- Sector – Increasing the gamut of products that are currently manufactured towards non-automotive customers
- Product – Diversification into high margin, niche products and EV

02



### Continued investment in innovation and technology

- Enhancing R&D capabilities to further provide competitive edge with respect to quality and cost
- Investment in modern technology and equipments solidifying the competitive edge

03



### Continued cost and process optimization

- Accelerated efforts to optimize and improve process efficiency
- Focus on achieving economies of scale
- Automation to increase productivity & decrease cost
- Increase Yields, decrease RMC

# Well positioned to capture future growth

- ❖ The forging capacity of the company will be augmented by 56,300 Tons by addition of warm forging press, upset forgings, 6000T press line
- ❖ The company has commissioned 23,800T of capacity as on 18<sup>th</sup> July 2023 and the remaining 32,500T will be commissioned by September 2023. In addition, the company has planned to setup cold forging capacity of 25,000T
- ❖ The Company has sufficient capacity for the next phase of healthy & robust growth.
- ❖ Capacity ramp-up along with operating leverage will result in faster improvement in profitability
- ❖ Future growth capex through internal accruals

## Installed Capacity (in Tons)\*

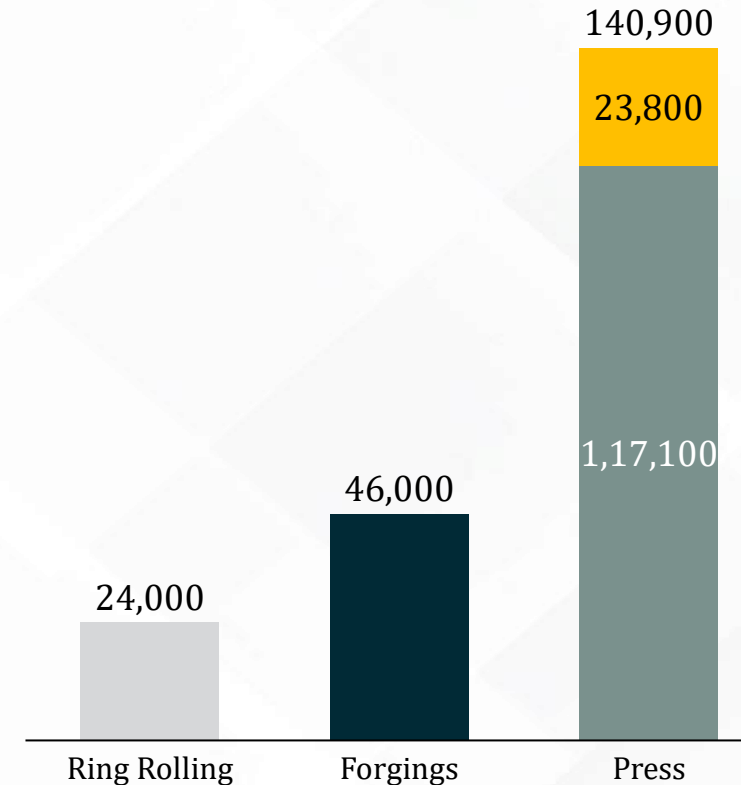

\*As on 18<sup>th</sup> July 2023

**Leveraging Free Cash Flows generated to Fund Growth Capex**

# Cold forgings capability



Total capacity of **25,000T** will be added

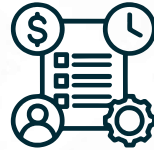

The total project cost for the project will be ₹ **125 Cr**



Cold Forging Press line to be commissioned by **Q1FY25**



Entire **100%** capacity has been booked by an OEM, the contract of the same is valid for **7 years**



# Strategic acquisition of Multitech Auto



## About Multitech Auto Private Limited

- Multitech Auto Pvt. Ltd. (MAPL), incorporated in 1994 in Jamshedpur as a Machine Shop to supply high quality Machined part, have over the years been able to set up a wholly owned foundry and a cold drawing Bright Bar Unit.
- With a single-minded focus towards enhancing value addition and customer engagement, MAPL embarked on a growth path by continually investing in technologies and skill development and today is regarded as the pioneers of high-quality SG and CI Castings and the first to introduce ADI castings in Eastern India. Now the company is one of the leading ADI Castings player in India.
- The manufacturing capabilities include Precision Machined Austempered Ductile Iron (ADI) Castings, Precision Machined SG & CI Castings from 1KG to 45KG Weights – 1800MT/Month, Bar Draw Facility with Capacity of 500 MT/ Month
- It is an IATF 16949:2016 certified company
- The company has a wide range of hi-tech, precision machined, heat treated and ground automobile components from bars, castings, primarily for brakes, gear boxes, axle and suspension parts of commercial vehicles and railway, having extensive and modern machining facilities, SCADA Controlled Heat Treatment facilities and well-equipped inspection facilities for metrological, material testing and verification
- The company Manufacture's machined cast parts for Medium and Heavy Commercial vehicles, Railways.

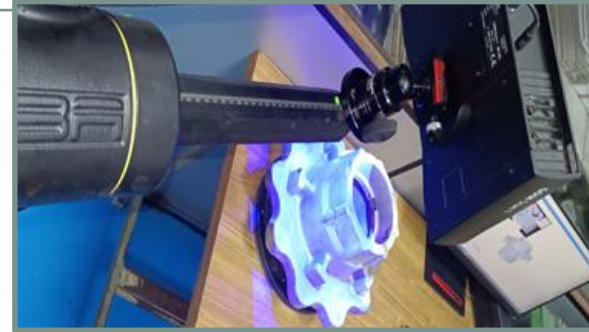

# Strategic acquisition of Multitech Auto



## Details & Rationale of the acquisition

- Ramkrishna Forgings (RKFL) to acquire Multitech Auto Private Limited and its wholly owned subsidiary Mal Metalliks Private Limited with a capacity to manufacture Machined SG & CI Castings and Bar Draw Facility
- This acquisition will help RKFL to manufacture and supply the entire differential assembly and trailer axle assembly consisting of Casting and Forgings.
- It will strengthen the presence of RKFL in Passenger Vehicles, Light Commercial Vehicles & Heavy Commercial Vehicles segment
- RKFL is also acquiring Mal Auto Products Private Limited with 10 acres land (4,30,000 sq. ft approx.) which will be used for further expansion
- This acquisition will aid further value add combined with forgings to be value accretive

## Way forward

- RKFL proposes to add further capacities in MAPL and take it to 70000 mtpa by FY 24-25 and to 100,000 mtpa by FY25-26, with these additional capacities RKFL aims to achieve a topline of Rs 1000 Crores in MAPL by FY25-26.
- Currently the EBITDA of MAPL is at 14%, RKFL aims to achieve an EBITDA of 18% by FY25-26

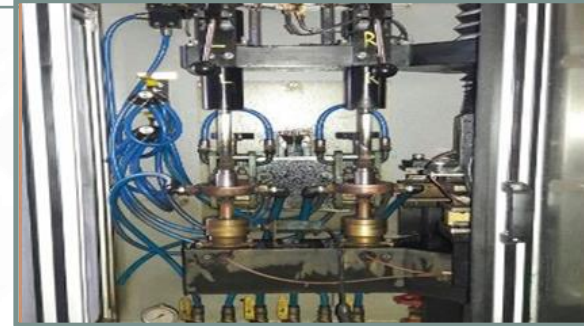

# Way Forward - RKFL's vision on acquiring MAPL

- Ramkrishna Forgings aims to enter in the manufacturing of Trailer Axle Assembly and Differential Assembly with this acquisition
- Market size of the Trailer Axle Assembly is about Rs. 8000 Crores per annum
- The company aims to capture 20% of market share of Trailer Axle Assembly in next 2/3 years

Trailer Axle Assembly



Differential Assembly



# Enhancing product portfolio by acquiring JMT Auto



## JMT Auto

- ❖ Lenders to JMT Auto have approved a resolution plan by Ramkrishna Forgings Limited
- ❖ The acquisition will help the company grow in terms of diversification & market reach as JMT Auto has significant expertise in the auto sector with capabilities in heat treatment and gear and in manufacturing a variety of components for the Oil and Gas industry
- ❖ The acquisition plan had been duly approved by 84.61% Committee of Creditors and has also been approved by NCLT Delhi on August 21, 2023
- ❖ As per the resolution, the company will make an upfront payment of Rs 70 Crores, with the remaining Rs 55 Crores to be paid over four years
- ❖ Additionally, the company will infuse Rs 50 Crores over two years for refurbishing plant and machinery
- ❖ The company plans to finance the acquisition through a combination of internal accruals and debt
- ❖ With this acquisition RKFL will manufacture engine products, Gear components, Axle components, Excavator components, Oil and Gas components and other components.
- ❖ JMT Auto's primary clientele in the domestic sector includes companies such as BEML, KOBELCO, Caterpillar, Cummins, L&T, and Komatsu, among others. In the international market, they serve clients like Halliburton, Daimler Chrysler, GM, Danfoss, and Massey Ferguson, to name a few.
- ❖ JMT Auto has 6 plants in Jamshedpur & 2 plants in Dharwad in western India
- ❖ The company aims to achieve a turnover of Rs 400-500 cr from JMT Auto by FY26

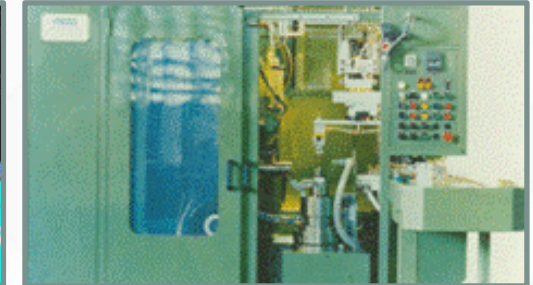

**JMT AUTO LTD.**

# Accelerated growth through inorganic route



## FORAYING INTO NEWER SEGMENTS

### ACIL

- ❖ Lenders to ACIL Ltd have approved a resolution plan by Ramkrishna Forgings Limited
- ❖ The acquisition will help the company to foray into Tractors and PV segments
- ❖ It will be a forward integration which will enable the company to supply machined crankshafts, camshafts for tractors, PV, HCV, LCV as well as two wheelers. Besides, the company also manufactures various products which are used in Tractors and PV
- ❖ The acquisition will be financed through internal accruals and debt
- ❖ As of now Supreme Court decision is awaited to initiate the acquisition process, which is expected in Q3FY24

**ACIL LTD.**

## EXPANDING THE EV PORTFOLIO

### RKFL - TSUYO

- ❖ Ramkrishna Forgings to acquire upto 51% voting rights in TSUYO Manufacturing”
- ❖ Ramkrishna Forgings approved an investment to acquire upto 51% voting rights of TSUYO Manufacturing Private Limited (“TSUYO”)
- ❖ It is a leading Mid-Drive BLDC, IPM and AC Induction based motor topologies & a Make-In-India start-up company engaged in powertrain solutions for electric vehicles
- ❖ It will aid in expanding its facilities for the manufacture of motors, controllers, E-axles, and differentials
- ❖ The Company plans to invest around Rs. 100 Crores over the next 5 (five) years that will generate a turnover of around Rs. 500 Crores by the end of the fifth year

**Tsuyo**

# Accelerated growth through organic route



## COMBINING FORCES FOR SUCCESS

### Rail Wheel Project

- ❖ Ramkrishna Forgings & Titagarh Rail Systems Consortium receives LOA for Manufacturing and Supplying of Forged Wheels for the Indian Railways
- ❖ Ramkrishna Forgings holds 51% in the Joint Venture and is a lead partner in this railway contract
- ❖ It will establish a manufacturing plant in India for the production of 200,000 forged wheels per annum
- ❖ Expected to start operation by end of FY26

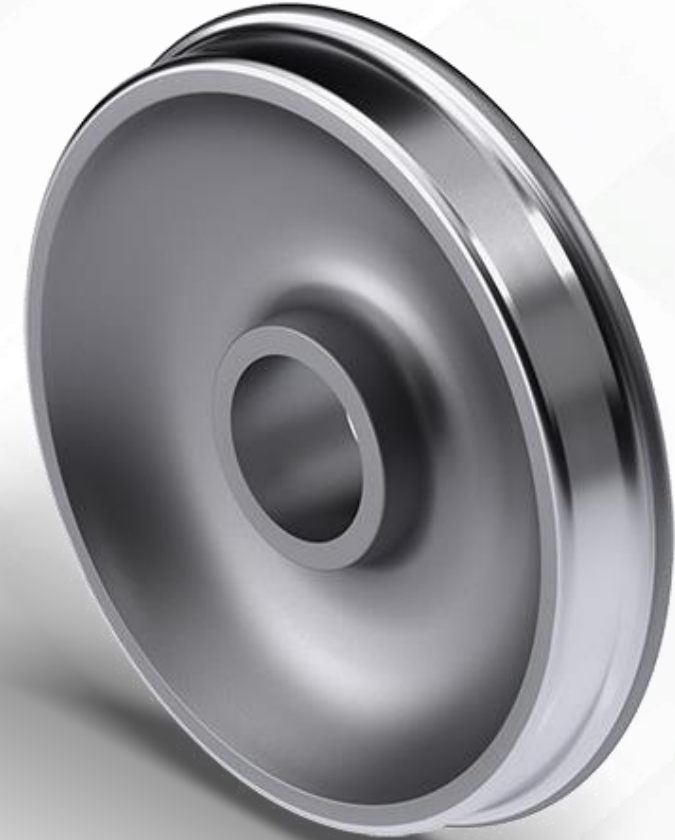

# EV programs running globally

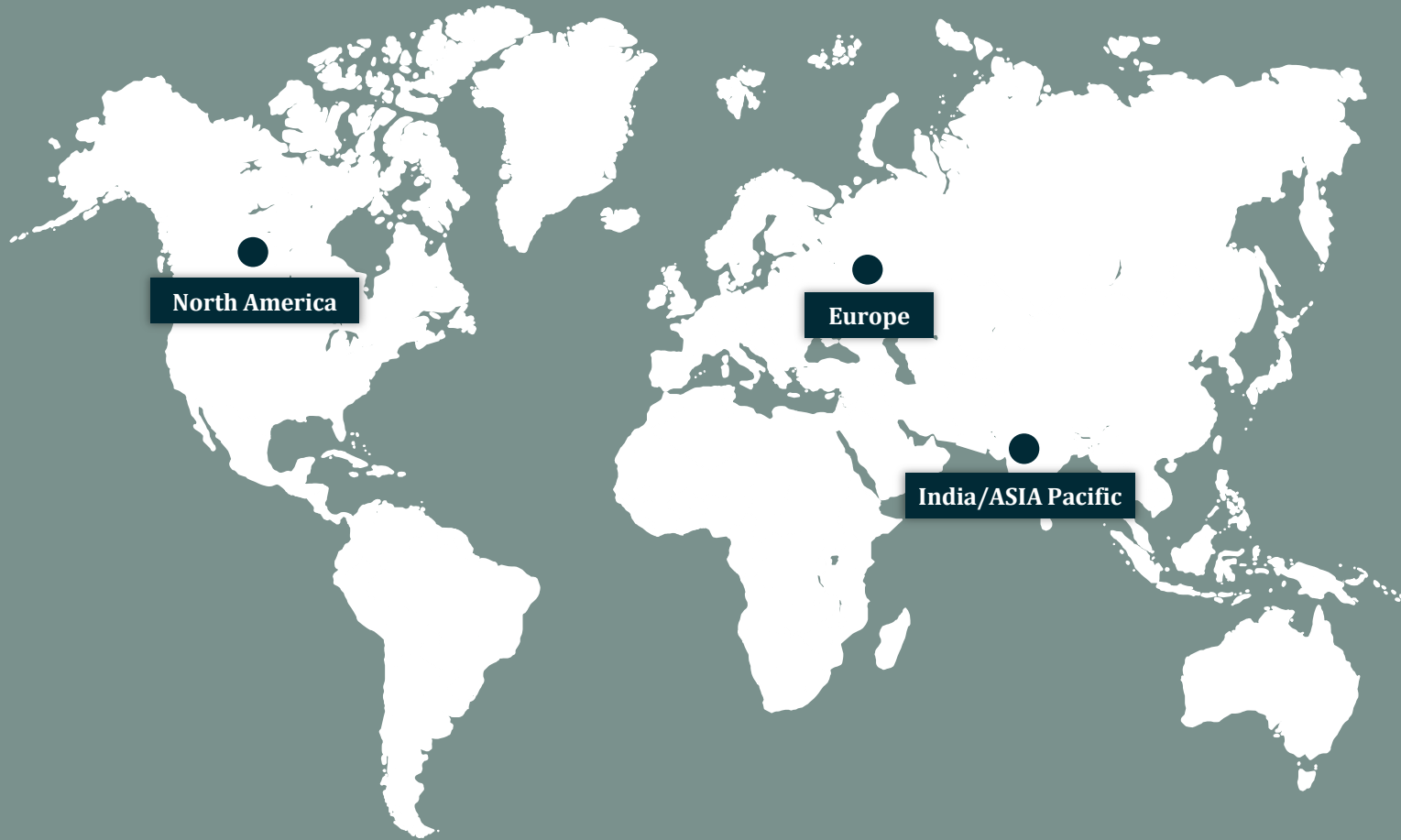

## India / Asia Pacific

5 Customer

- ❖ 7 Programs
- 6 Programs

## Europe

2 Customer

- 3 Programs

## North America

1 Customer

- ❖ 5 Programs
- 4 Programs

- ❖ Programs in Serial Productions
- Programs in Order book

➤ Swedish OEM awards business worth 15 million Euros for component to their EV truck for European Market to commence their development & supplies till 2030 for the awarded business.



# Financial Performance



# Key performance indicator (Standalone)

(₹ in lakhs)

## Revenue\*

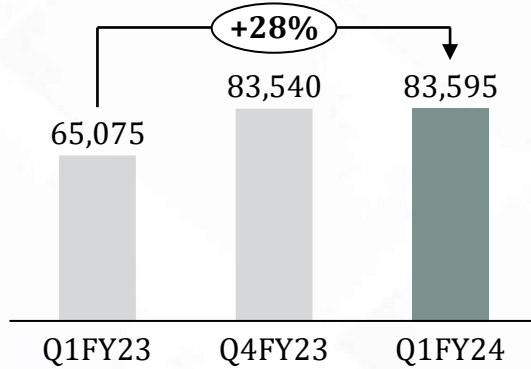

## EBITDA\* & EBITDA Margin

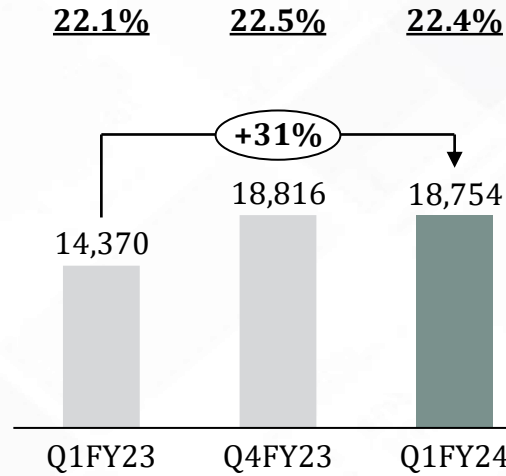

## PAT & PAT Margin (%)

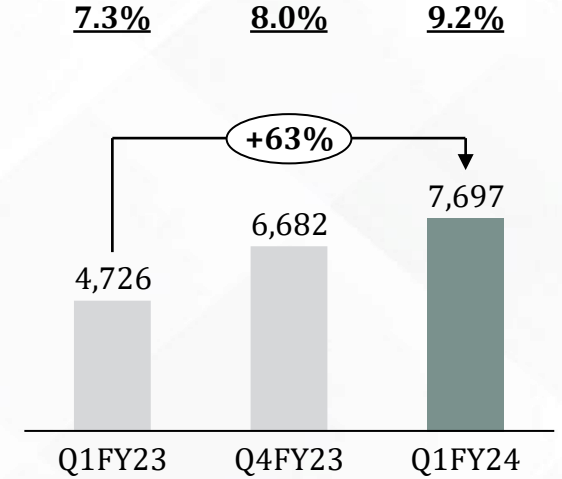

## Revenue\*

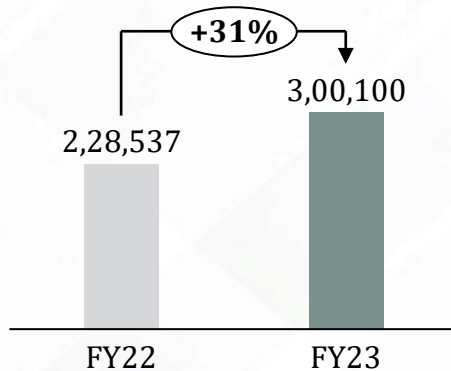

## EBITDA\* & EBITDA Margin

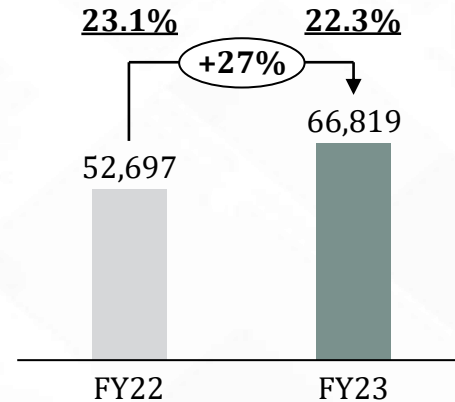

## PAT & PAT Margin (%)

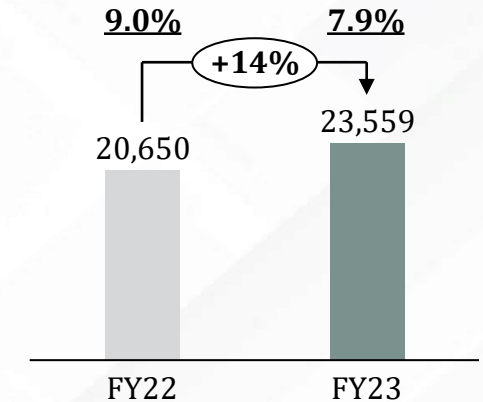

\*Excluding Other Income ; Note: Rounded off to the nearest whole number

# Key performance indicator (Consolidated)

(₹ in lakhs)

## Revenue\*

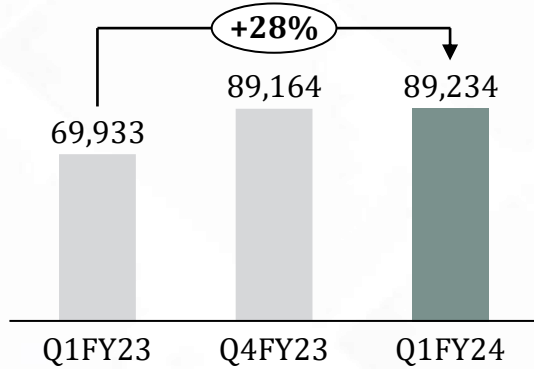

## EBITDA\* & EBITDA Margin

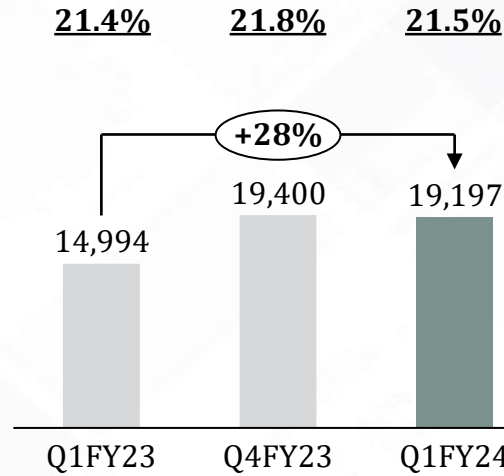

## PAT & PAT Margin (%)

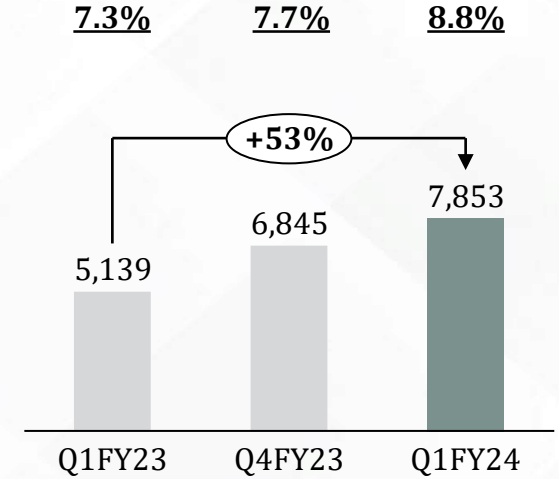

## Revenue\*

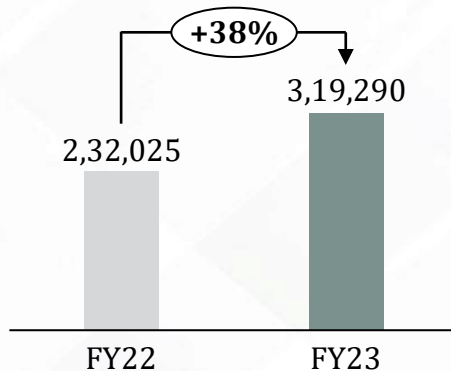

## EBITDA\* & EBITDA Margin

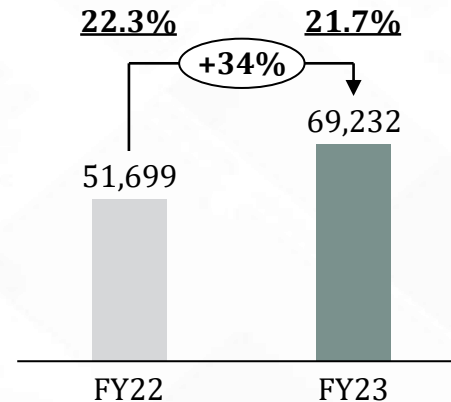

## PAT & PAT Margin (%)

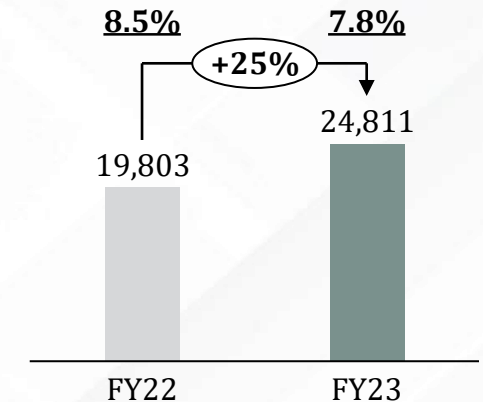

\*Excluding Other Income ; Note: Rounded off to the nearest whole number

# Income Statement



Particulate (₹ in lakhs)	FY19	FY20	FY21	FY22	FY23
<b>Revenue from Operations</b>	<b>1,80,669</b>	<b>1,11,182</b>	<b>1,28,838</b>	<b>2,28,537</b>	<b>3,00,100</b>
Cost of Goods Sold	92,650	50,673	64,240	1,03,077	1,44,374
<b>Gross Profit</b>	<b>88,019</b>	<b>60,509</b>	<b>64,597</b>	<b>1,25,459</b>	<b>1,55,725</b>
<b>Gross Profit Margin</b>	<b>48.7%</b>	<b>54.4%</b>	<b>50.1%</b>	<b>54.9%</b>	<b>51.9%</b>
Employee Cost	9,682	9,424	9,037	12,028	14,431
Power and Fuel	14,248	9,719	9,354	15,240	18,792
Other Expenses	26,139	20,995	23,214	45,493	55,683
<b>EBITDA</b>	<b>37,950</b>	<b>20,372</b>	<b>22,993</b>	<b>52,697</b>	<b>66,819</b>
<b>EBITDA Margin</b>	<b>21.0%</b>	<b>18.3%</b>	<b>17.9%</b>	<b>23.1%</b>	<b>22.3%</b>
Other Income	299	602	461	161	377
Depreciation	12,083	12,016	11,628	16,906	20,135
<b>EBIT</b>	<b>26,166</b>	<b>8,957</b>	<b>11,826</b>	<b>35,952</b>	<b>47,061</b>
<b>EBIT Margin</b>	<b>14.5%</b>	<b>8.1%</b>	<b>9.2%</b>	<b>15.7%</b>	<b>15.7%</b>
Finance Cost	7,922	7,515	7,678	9,335	11,496
Exceptional Item Gain / (Loss)	-	-	-	-	-
<b>Profit before Tax</b>	<b>18,244</b>	<b>1,442</b>	<b>4,148</b>	<b>26,617</b>	<b>35,565</b>
<b>Profit before Tax Margin</b>	<b>10.1%</b>	<b>1.3%</b>	<b>3.2%</b>	<b>11.6%</b>	<b>11.9%</b>
Tax	6,313	480	1,352	5,967	12,005
<b>Profit After Tax</b>	<b>11,931</b>	<b>961</b>	<b>2,796</b>	<b>20,650</b>	<b>23,559</b>
<b>Profit After Tax Margin</b>	<b>6.6%</b>	<b>0.9%</b>	<b>2.2%</b>	<b>9.0%</b>	<b>7.9%</b>

# Balance Sheet



Particulate (₹ in lakhs)	FY19	FY20	FY21	FY22	FY23
Net block (Tangible assets)	123,445	137,376	149,385	155,903	173,955
Intangible assets	145	922	1,088	3,171	3,041
Investments	1,930	1,930	1,938	1,938	1,939
Other non-current assets	5,323	4,274	3,174	7,111	9,543
<b>Total non - current assets</b>	<b>130,843</b>	<b>144,502</b>	<b>155,585</b>	<b>168,123</b>	<b>188,478</b>
Inventories	33,126	35,719	42,994	68,267	86,852
Investments	0	0	0	5,500	0
Trade receivables	46,604	30,260	55,993	87,781	72,536
Cash and cash equivalents	248	233	6,680	3,237	4,247
Other current assets	4,088	7,049	6,671	10,704	10,946
<b>Total current assets</b>	<b>84,066</b>	<b>73,261</b>	<b>112,338</b>	<b>175,489</b>	<b>174,581</b>
<b>Total assets</b>	<b>214,909</b>	<b>217,763</b>	<b>267,923</b>	<b>343,612</b>	<b>363,059</b>
<b>Total equity</b>	<b>87,290</b>	<b>87,643</b>	<b>88,997</b>	<b>109,408</b>	<b>132,492</b>
Borrowings	45,816	47,903	66,360	85,945	75,092
Lease liabilities		353	378	2,280	2,054
Other non-current liabilities	7,687	7,622	8,287	9,495	16,077
<b>Total non-current liabilities</b>	<b>53,503</b>	<b>55,878</b>	<b>75,025</b>	<b>97,720</b>	<b>93,223</b>
Borrowings	33,207	36,425	54,160	71,794	49,008
Lease liabilities		40	22	429	550
Trade payables	26,472	20,693	42,916	57,457	76,614
Other current liabilities	14,437	17,084	6,803	6,804	11,172
<b>Total current liabilities</b>	<b>74,116</b>	<b>74,242</b>	<b>103,901</b>	<b>136,484</b>	<b>137,344</b>
<b>Total equity &amp; liabilities</b>	<b>214,909</b>	<b>217,763</b>	<b>267,923</b>	<b>343,612</b>	<b>363,059</b>

# Cash Flow Statement



Particulate (₹ in lakhs)	FY19	FY20	FY21	FY22	FY23
<b>Cash Flow from Operating Activities</b>					
Profit before Tax	18,244	1,442	4,148	26,617	35,565
Adjustment for Non-Operating Items	18,022	17,667	18,453	23,592	26,758
<b>Operating Profit before Working Capital Changes</b>	<b>36,266</b>	<b>19,109</b>	<b>22,601</b>	<b>50,210</b>	<b>62,322</b>
Changes in Working Capital	-4,841	6,678	-9,394	-41,746	22,177
<b>Cash Generated from Operations</b>	<b>31,425</b>	<b>25,786</b>	<b>13,207</b>	<b>8,464</b>	<b>84,499</b>
Less: Direct Taxes paid	-4,148	-670	-557	-4,556	-6,724
<b>Net Cash from Operating Activities</b>	<b>27,277</b>	<b>25,116</b>	<b>12,650</b>	<b>3,908</b>	<b>77,776</b>
<b>Cash Flow from Investing Activities</b>	<b>-25,385</b>	<b>-22,493</b>	<b>-22,622</b>	<b>-35,348</b>	<b>-29,727</b>
<b>Cash Flow from Financing Activities</b>	<b>-1,735</b>	<b>-2,590</b>	<b>16,405</b>	<b>27,884</b>	<b>-47,057</b>
<b>Net increase/ (decrease) in Cash &amp; Cash equivalent</b>	<b>157</b>	<b>33</b>	<b>6,432</b>	<b>-3,556</b>	<b>992</b>
Add: Cash and cash equivalents as at 1st April	37	194	226	6,659	3,102
<b>Cash and cash equivalents as at 31st March</b>	<b>194</b>	<b>226</b>	<b>6,659</b>	<b>3,102</b>	<b>4,094</b>



# Our Commitment





## ENVIRONMENTAL CONSCIOUSNESS

We will take sustained efforts towards creating a healthy planet by reducing our carbon footprint, mitigating climate change and optimizing our business operations



## ROBUST GOVERNANCE

Following an effective governance model and focus on business integrity to achieve business & sustainability goals



## VALUABLE PARTNERSHIPS

Develop relationships with our suppliers through assessments, collaborations, capacity building and develop a resilient supply chain



## REWARDING WORKPLACE

We value a diverse workforce and work towards creating a healthy workplace where talent is developed, recognized and rewarded



## EMPOWERED COMMUNITIES

Ensuring positive relationships with our communities and contributing to their welfare by reducing inequality, promoting education, health and gender equality

# Preserving and protecting the environment across our operations (1/2)



## Our Targets



**Carbon Neutral**

across scope 1 & 2 by 2050



**50%**

of energy use will be from renewable sources by 2028



**100%**

recycling of water for use by 2025



**50%**

decrease in overall waste through the 3R approach

## Key Initiatives

### 01 Waste & Water Management

- Setting up an **effluent treatment plant, sewage treatment plant and cooling tower, compressor** on our plant premises

	Plant 5	Plant 7
ETP	150 KLD	100 KLD
STP	62 KLD	65 KLD

- Recycling 71,000 litres of water per day**

### 02 Product Stewardship

- Conducting **Life Cycle Assessment** for three of our products - front axel beam, crown wheel and knuckles by considering **impact at each stage of the product's life cycle** from raw material extraction to transportation, product use and disposal



# Preserving and protecting the environment across our operations (2/2)



## Key Initiatives

### 03 Energy Optimisation

- Developed a carbon-neutral strategy wherein key levers for decarbonisation are **optimizing energy use, transitioning to renewable energy, switching to zero carbon fuel and carbon offsets**

Identified initiatives for emission reduction including –

- Renewable energy power procurement inline with RE100
- Replacement of **motors under NMRP\***
- Optimising **cooling tower** functionalities
- Retrofitting compressors with VFD\*\*** for unloading power optimization

- Setting up an 8MW solar power plant** in our Jamshedpur Plant through an approximate investment of INR 30 Cr, in addition to the existing 1MW solar plant.

Category-wise emissions (tCO2e) in FY2022-23

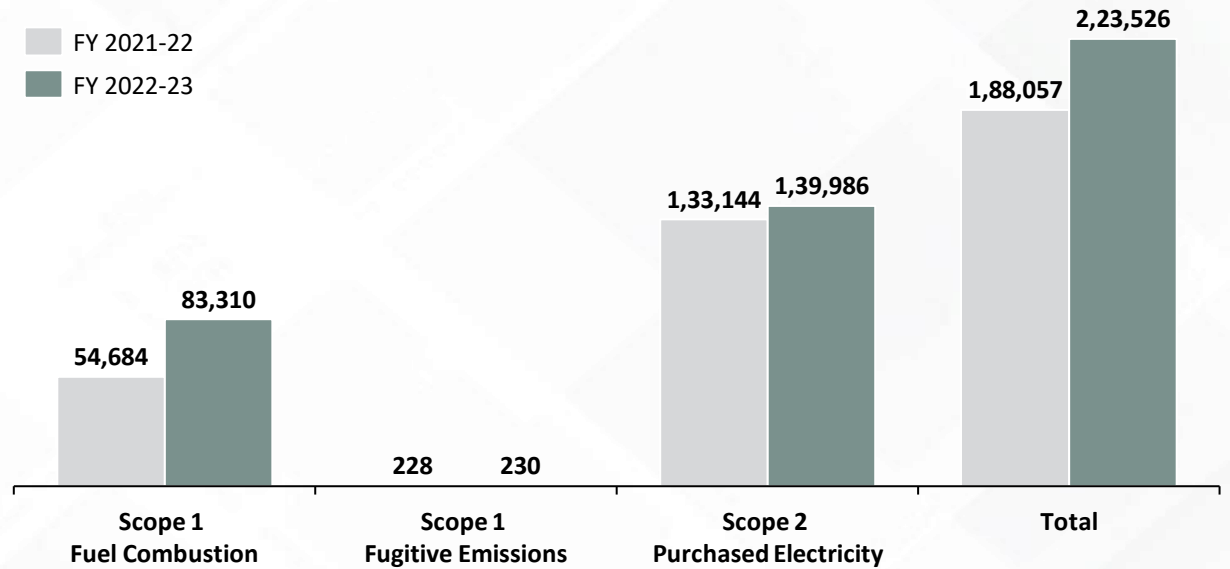

# Aspiring to be employer and partner of choice

## Our Targets



55%

increase in employee volunteering participation by 2030



Well Being

program focused on employees' mental and physical health will be launched in 2023



Supply Chain

framework to work with supplier responsibly

## Key Initiatives

### 01 Responsible Supply Chain Management

- **Categorised suppliers based on criticality** using factors such as business volume, procurement spent, non-substitutability & price sensitivity
- Planning to conduct sample supplier audits which will help **evaluate suppliers on ESG parameters**
- **Refreshing Supplier Quality Manual** to include sustainability as a parameter in vendor evaluation

### 02 Employee Development

- Conducted **training sessions** on ESG Awareness, Human Rights and Diversity, Equity & Inclusion across all our plants
- Introducing **Capacity Building Workshop** on Employee Code of Conduct & Supplier Quality Manual to create a robust & ethical working environment



# Aspiring to be employer and partner of choice



## Our Targets



10%

increase in representation of women in our leadership by 2030



Train

all permanent employees to live the values set out in the Code of Conduct



Raise the Bar

to drive business growth and deliver on our ESG Vision

## Key Initiatives

### 01 Policy Information

- Refreshed **Corporate Responsibility Policy** as per Ministry of Corporate Affairs Companies (Corporate Social Responsibility Policy) Amendment Rules, 2022
- Introduced **Stakeholder Engagement Approach** which includes details of engagement priority concerns, channels & frequency
- Reviewing existing policies on **POSH & whistle-blower mechanism**
- Introducing a new policy on **customer grievance redressal**



This presentation and the accompanying slides (the “Presentation”), which have been prepared by **Ramkrishna Forgings Limited** (the “Company”), have been prepared solely for information purposes and do not constitute any offer, recommendation or invitation to purchase or subscribe for any securities, and shall not form the basis or be relied on in connection with any contract or binding commitment whatsoever. No offering of securities of the Company will be made except by means of a statutory offering document containing detailed information about the Company.

This Presentation has been prepared by the Company based on information and data which the Company considers reliable, but the Company makes no representation or warranty, express or implied, whatsoever, and no reliance shall be placed on the truth, accuracy, completeness, fairness and reasonableness of the contents of this Presentation. This Presentation may not be all inclusive and may not contain all of the information that you may consider material. Any liability in respect of the contents of, or any omission from, this Presentation is expressly excluded.

Certain matters discussed in this Presentation may contain statements regarding the Company’s market opportunity and business prospects that are individually and collectively forward-looking statements. Such forward-looking statements are not guarantees of future performance and are subject to known and unknown risks, uncertainties and assumptions that are difficult to predict. These risks and uncertainties include, but are not limited to, the performance of the Indian economy and of the economies of various international markets, the performance of the industry in India and world-wide, competition, the Company’s ability to successfully implement its strategy, the Company's future levels of growth and expansion, technological implementation, changes and advancements, changes in revenue, income or cashflows, the Company's market preferences and its exposure to market risks, as well as other risks. The Company's actual results, levels of activity, performance or achievements could differ materially and adversely from results expressed in or implied by this Presentation. The Company assumes no obligation to update any forward-looking information contained in this Presentation. Any forward-looking statements and projections made by third parties included in this Presentation are not adopted by the Company and the Company is not responsible for such third-party statements and projections.

All Maps used in the Presentation are not to scale. All data, information and maps are provided "as is" without warranty or any representation of accuracy, timeliness or completeness.

**THANK YOU**

COMPANY :



Ramkrishna Forgings Limited

CIN : L74210WB1981PLC034281

Mr. Lalit Kumar Khetan (Whole Time Director & CFO)

E: [lalit.khetan@ramkrishnaforgings.com](mailto:lalit.khetan@ramkrishnaforgings.com)

[www.ramkrishnaforgings.com](http://www.ramkrishnaforgings.com)

INVESTOR RELATIONS ADVISORS :



**Orient Capital (a division of Link Group)**

Mr. Nikunj Jain

+91 9769060608

[nikunj.jain@linkintime.co.in](mailto:nikunj.jain@linkintime.co.in)

Mr. Amar Yardi

+91 7045121239

[amar.yardi@linkintime.co.in](mailto:amar.yardi@linkintime.co.in)